

Color Acquisition Device (CAD)

Spring 2021

Group 3

Kyle Hoofman - Electrical Engineering

Cesar Lopez-Zelaya - Photonic Science and Engineering

Noah Richter - Photonic Science and Engineering

David Rothaus - Electrical Engineering

Sponsors:

Air Force Research Laboratory (AFRL)



University of Central Florida (UCF) Professors:

Dr. Peter Delfyett

Dr. Guifang Li

Dr. Kyle Renshaw



UCF

Table of contents

1. Executive Summary	1
2. Project Description	3
2.1 Motivation	3
2.2 Goals	4
2.3 Engineering Specification	6
2.4 Block Diagram	8
3. Research and Part Selection	20
3.1 Technology Comparison	20
3.3 Strategic Optical Components	27
3.4 Relevant Electrical Technologies	32
3.4.2 Serial Communication Technologies	33
3.4.3 SPI	34
3.4.4 UART	36
3.4.5 I2C	39
3.4.6 Comparison of Serial Communication Protocols	41
4 Design Constraints and Standard (10-15 page)	43
4.1 Related Standards	43
4.2 Relevant Standards	44
4.3 Design Impact of Relevant Standards	48
4.4 Realistic Design Constraints	50
4.5 Economic and Time Constraints	53
4.6 Environmental, Social and Political Constraints	54
4.7 Ethical, Health, and Safety Constraints	55
4.7 Manufacturability and Sustainability Constraints	57
5 Design (25-30 pages)	62
5.1 System Overview	62
5.2 Optical Subsystem Overview	64
5.3 Telesto Laser	66
5.4 Collimation & Alignment Optics	69
5.5 Polarization Optics	71
5.6 Optical Fibers	73
5.7 Calibration Setup	75
5.8 Application Setup	76
5.9 Electrical Subsystem Overview	77

5.10 Microcontroller And External Modules	79
5.10.2 External Module Parts Selection	82
5.10.3 Selected External Modules	85
5.11 Hardware Design (15-20)	86
5.11.1 Power System	88
5.11.2 Microcontroller Module	89
5.11.3 Headers	95
5.11.4 Bill of Materials	99
5.11 Software and Interface (10-20)	99
5.11.1 MATLAB Software Design	99
5.11.2 Microcontroller Software Design	103
6 Overall Integration, PCB Design and System Testing	106
6.1 Optical Test Environment	106
6.2 Electrical Hardware Test Environment	107
6.3 Printed Circuit Board (PCB) design	109
6.3.1 Board Design	110
6.4 Electrical Hardware Testing	112
6.5 Optical Hardware Testing	114
7. Administration. (5-10 pages)	117
7.1 Milestone Discussion	117
7.2 Budget and Finance Discussion	119
8. Conclusion	124
Appendix	127
A1 Works Cited	127
A2 Datasheets	128

1. Executive Summary

Laser detection and ranging (LADAR) is a method of measuring distances by illuminating a target with laser light and collecting the reflection with a sensor. Devices and systems that take advantage of this ranging technique are capable of mapping entire scenes by measuring the total travel time of light and knowing its speed. Some potential applications of these technologies are archaeology, self driving cars, and surveillance.

Conventional LADAR devices are limited to operating at a single wavelength, restricting their application to ranging, which comes with limitations. A single wavelength is enough for mapping and range estimation, but it might not be able to penetrate some obstructions or the resolution of the LADAR system might be limited (e.g. in a complex urban scene or jungle where a lot is going on); thus making it hard to distinguish objects in a scene. Detection capabilities can be further improved by introducing additional wavelengths into the system. These additional wavelengths are capable of providing multispectral measurements, thus improving object detection and classification; especially when the system cannot make out the full object shape as with traditional LADAR.

Several methods exist to make a laser go from emitting a single wavelength, to multiple ones. We propose designing, building, and prototyping a one-of a kind multispectral Raman-based fiber-laser system capable of emitting multiple wavelengths at once, as well as being able to obtain spectral reflectivity measurements and estimating range. This can be done by knowing the different shapes, in time, of the wavelengths generated by stimulated Raman scattering (SRS) without the need of any additional cavities, dispersive, bulky, and expensive optics. Thus, a revolutionizing low cost, size, weight, and power (CSWaP) laser system is proposed.

By pumping a polarization-maintaining single-mode (PM-SM) optical fiber with a 3-5ns pulse, 20KHz repetition rate, $1\text{GW}/\text{cm}^2$ peak power density, $1.064\mu\text{m}$ wavelength fiber-laser, the first Stokes (lower-energy) wavelength should become apparent. Extending the optical fiber beyond its calculated threshold length of 16.3m, while maintaining all else the same, higher-order Stokes wavelengths begin to experience higher gain as well. This occurs because of the increased interactions of the generated Stokes waves along the length of the longer fiber. A cascading effect results from this interaction, where the pump generates the first Stokes wave and this Stokes wave becomes the new pump for the second Stokes wave, and so on. This effect yields sets

of frequencies 13THz apart from each other that can easily be separated spatially by using a grating and characterized individually.

By characterizing the system correctly with a high-bandwidth analog to digital converter (ADC), the shape of each of the waves in time, including the pump, can be individually analyzed. By knowing these shapes and their relative intensities, spectral measurements can be taken from objects and scenes by directing the laser beam appropriately, measuring the reflected light, and comparing it to the original output data (wavelengths and temporal shapes) from the Raman-active fiber. This step ensures that the laser system does not need additional diffractive elements because of each wavelength's unique temporal shape.

The custom PCB will feature an ATMEL ATmega328P-PU that is used on many arduino boards such as the Arduino UNO rev 3, a bluetooth module capable of 10 meters of free space communication, and an 20x4 LCD display that is easy to read and can output a significant amount of information. We will also be designing a small power supply that will be included in the custom PCB microcontroller. This power supply will get its power from a 9 volt battery. The custom PCB design will be designed on Autodesk EAGLE using references from various sources online who have worked with the Arduino platform along with reference material from the Arduino company itself. All these components together insure that a user will be able to access information about what our laser system is classifying while being mobile and not tethered to the post processor or a computer. LADAR has come very far from its inception, but we hope to bring it to the next level with the ability to utilize Raman lasers for object classification and detection.

The end goal of this laser system is to be able to not only detect different spectral signatures, but to measure the distance to the target (optionally) and let the user know that a spectral anomaly (change in the targets reflectivity spectrum) is present; e.g. if the target were to slightly change, if something different than what was originally scanned in the target is present, the device would be able to detect those anomalies and report them to the user. This post processing will be done on a computer through matlab or python. The computer will take the outputs from the oscilloscope and apply signal processing techniques to provide us with more comprehensive information about the waveforms received from the sensors. After the signal processing is achieved the computer will send information over bluetooth to a custom PCB microcontroller that will display information such as range and possible material composition.

2. Project Description

2.1 Motivation

The discovery of the laser in the 1960s was a pivotal event in science, technology, and engineering. Before this, monochromatic and coherent sources of light were not as good and required the use of filters and complicated optics to achieve. Following the 1960s, a great number of technologies began emerging due to lasers becoming mainstream. One big driving factor for this was the fact that these devices were highly coherent, monochromatic, and they could be engineered to emit light of different wavelengths. Many applications and devices were born from this technology, such as CD players, barcode scanners, medical lasers (for eye surgery, tissue repairs, and microscopy), displays, and rangefinders, to name a few. In fact, many of the devices that use these technologies are actually manufactured by using lasers due to how precise they are.

Knowing that lasers are used so much in our day-to-day lives, there have to be different types which are designed and engineered depending on the application. Some laser types are gaseous, solid-state, dye, semiconductor, and fiber-based. For example, laser pointers use semiconductor lasers, some laser cutters use CO_2 gas while others are fiber-based, and some rangefinders use solid-state lasers to be able to send light far distances and measure range. Despite it sounding easy to be able to mount any kind of laser onto anything, there are some limitations, however. Some lasers don't have high gain, which limits their output power, thus making them undesirable for some applications. Others are too bulky and depending on the application, they are not suitable.

A new technology that was born from the needs of rangefinding was laser detection and ranging (LADAR). This technology can use one or multiple lasers to map and characterize a scene. Just like with conventional radar, LADAR systems can detect and identify objects in a scene. Since LADAR devices use optical wavelengths, they tend to have better longitudinal and transverse resolutions than their long-wave counterparts (radars).

Like mentioned before, one of the greatest advantages that laser systems have is how monochromatic they are. For some applications, however, this can be a bottleneck in performance. This means that a system like LADAR, for example, is limited by operating at a single wavelength. A good example of this is the characterization of a scene. Some objects might be behind an obstacle, or even detected, but the system will not be able to tell an object apart from the background. Also, objects absorb some

wavelengths more than others and this can be used to further help the LADAR system identify what it's looking at. If the objective is to not only map, but to identify a specific object in the scene, using different wavelengths while knowing the object's reflectivity data will make it possible to find a specific target.

Due to the novelty of this technology, our group will be engineering and devising a laser system capable of emitting different wavelengths that will be used in collecting the spectral reflectivity information of materials and scenes, with the added benefit of being able to measure range. The process will go as follows, the laser fires multispectral Raman-based waveforms that travel through space to the object, then the waveforms are reflected from the object back through space to our detector which feeds the information to an oscilloscope. The information from the oscilloscope is then sent to a computer from which we will use python or matlab to run signal processing algorithms to interpret the data. This interpreted data will then be used to determine range and object classification. The object classification will be done by comparing the received data to previous data we have recorded by testing of different materials. Then the computer will send this information to our custom PCB microcontroller unit which will accurately display the range and potential material composition on a display in an easy to read format.

To make this device simple, low-cost, and lightweight, we will use stimulated Raman scattering to generate multiple wavelengths in a 100m long silica fiber. The wavelengths generated in this fiber will have different shapes in time, which can be detected by a single detector/digitizer, and post processed by using a computer and running signal processing algorithms. With the collected reflectivity data stored in the memory of the computer. The system identifies an object with the same spectral content stored, the computer will be able to determine the object that it identified. Then this information will be sent via bluetooth to our custom PCB microcontroller unit and displayed on an OLED screen. This simple, straightforward, and compact design eliminates the need for additional laser cavities and bulky optics used to separate the wavelengths in space and makes it possible to collect data and then identify objects.

Our goal for this project is to show that by using multispectral Raman based waveforms we can calculate the distance to an object while also determining the material composition of an object. This project will show that LADAR can go beyond just determining the range of an object and we hope it will encourage further development of LADAR technology.

2.2 Goals

The main goal of our project is to create a multispectral Raman-based fiber-laser with detectors and a post-processor that will be able to classify objects. Our

post-processor will use signal analysis algorithms on the waveforms so we can better interpret the data and output information such as the range and material composition of the object that is targeted by our laser. We will take some predetermined objects such as a piece of plywood or a rubber ball and put them in front of our laser and the device will output the differing distance and material composition on an LCD screen. We want our device to detect the range and the spectral reflectivity of materials as accurately as possible, as it is important that our device reaches the standards of current LADAR technologies while also pushing the boundaries of what LADAR is capable of. The following is a list of goals about what the device will be capable of doing. It is divided into main goals and stretch goals, where main goals are the ones we want to meet and stretch goals are optional, but will make the device better nonetheless.

Main goals:

- Design, build, and test a device that takes advantage of a temporally multiplexed Raman laser to characterize different objects (i.e. dirt and vegetation) with a single fiber-coupled high-speed detector.
- Effectively design and build a fiber laser system that will output multiple Stokes wavelengths via SRS to be used for classifying objects by shining them with the multispectral beam and measuring the reflectivity with an oscilloscope.
- After post-processing is done with a computer, the data will be sent via a Bluetooth module to the circuit board. This circuit board will be able to display the output data on an LCD screen. The output data will be the object that the program recognizes and its reflectivity values for the different Stokes wavelengths.

Stretch goals:

- Pump the fiber with strong enough power to get up to the 4th Stokes order wavelength. This would help with improving detection capabilities, but we have to be careful with spectral broadening.
- Measure range. This can be done in two ways, oscilloscope triggering or by using a simple time of flight (TOF) sensor. The first method relies on triggering the oscilloscope with the outgoing laser pulses from the pump laser and comparing the signal delay from the Raman fiber to object output. Then make a program where $d=ct$ is used to find the total distance that light traveled. The TOF sensor with a built in laser can easily be incorporated in the electrical system and can be used to detect range separately. This information will also be displayed in the LCD if implemented.

2.3 Engineering Specification

The Raman Fiber-Laser Based Object Classifier and Detector has a multitude of requirements that have to be met in order to ensure the functionality, accuracy, safety and other important criteria. The product is designed to be simpler and cheaper compared to conventional spectral measurement and ranging devices. In order to accomplish this certain trade offs will be necessary as a balance must be struck between effectiveness and price. Our requirement specifications can be divided into functionality, portability, economic, user interface, safety, environmental, and assignment.

Functional Requirements

- This system will be capable of registering and storing spectral reflectivity data from specific objects such as dirt, plants, and leaves. In addition, this device will be able to make an inference as to what it detects based on the spectral reflectivity signature of the object being scanned.
- All optical components used need to be able to withstand a high power and be optimized for the wavelength output of the pump laser.
- Electrical system should be able to display the object and reflectivity content. In addition, range is an option.

Portability Requirements

- It should be able to be brought into a variety of situations and environments
- The system should fit within an optical breadboard, enclosure, or at least the amount of space on a small optical table.
- The system should not exceed a weight that makes it unwieldy.
- Its size should be such that it should be mountable on a vehicle.

Economic Requirements

- The design should be such that it is cheaper than conventional methods.
- No need for expensive dispersive optics.
- All parts must be approved by the Air Force Research Laboratory (AFRL).

User Interface Requirements

- The system must have an easy to use and functional user interface.
- The signal processing side of the project must be to be able to display the waveforms clearly.
- Desired data should be easy to retrieve and extract.

- Data should be easy to interpret; it should not be too laborious to identify the target's spectral signature due to the temporal nature of the Raman-based waveforms.

Safety Requirements

- The output power does not exceed dangerous levels
- The lab should be secured to ensure no stray beams can reflect outside the facility
- Laser safety signs should be used at all times when the laser is in use.
- The beams should be well contained and avoid unwanted reflection
- Proper eyewear must be used at all times
- All wiring should be properly contained and managed
- All Standard Covid-19 procedures should be followed during the construction including, proper distancing, mask usage, and communication about current health status

Environmental Requirements

- All components featured consist of low environmental impact materials made in a responsible manner.
- All waste and any hazardous material is disposed of properly

Assignment Requirements

- The system must be designed using known processes and methods so that it does not constitute a research project
- All project details and process should be documented and properly organized
- The system must contain a balance of electrical and optical components
- There must be enough work for all group members to participate
- The project must include a designed PCB and breadboard to meet electrical requirements

House of quality

As we design our project, comparing the positive and negative qualities associated with both the marketing and engineering aspects of the project. By displaying this with a single table, it makes it easier to differentiate between our requirements quickly. We need to know how to prioritize different specifications. The goal of this laser system is to be able to detect different spectral signatures so to differentiate between objects while also being able to measure the distance to a target. To do this we must measure marketing and engineering requirements against each other. This will help us identify

what is important in the creation of our device. Below is a house of quality for our Multispectral Raman fiber-laser for object classification and detection device.

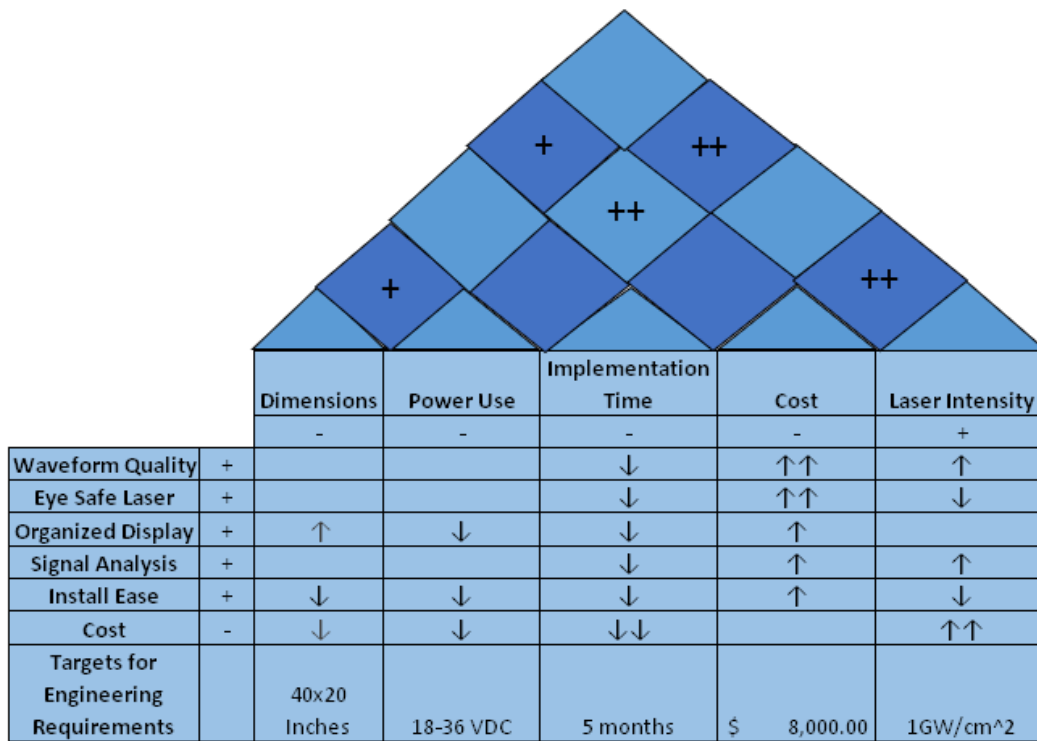

Legend:	
+	Positive Polarity
-	Negative Polarity
↑	Positive Correlation
↑↑	Strong Positive Correlation
↓	Negative Correlation
↓↓	Strong Negative Correlation

Fig. 1: House of quality diagram.

2.4 Block Diagram

Electro-optical systems, as the name implies, are composed of optical and electrical components. Bridging the gap between these two technologies is often a difficult task, such is the case for the system that we are designing, called CAD. Fortunately, with the use of high-speed InGaAs detectors, a high-bandwidth oscilloscope, and a laptop with Matlab it is possible to turn laser pulses that are a billionth of a second in width,

repeating twenty-thousand times per second into readable electrical inputs that we can then post-process and use to our advantage. Traditionally, spectroscopic techniques involving Raman scattering are employed in wavelength space, that is, using a laser to probe a sample, an inelastic scattering of light occurs and the wavelengths produced by the probed sample are dispersed using a diffraction grating. Then, by detecting them using a spectrometer, that sample can be characterized due to it having a unique emission spectrum.

Another way of doing this is by obtaining the spectral reflectivity information of a sample by shining it with a broadband laser source or multiple lasers. This technique can and has been used in LADAR technologies (discussed more in depth in chapter 3), which is the main motivation of our project. Our main goal is to make an electro-optical device capable of obtaining the spectral reflectivity information of different objects, such as plants and soil, and display this information to the user with an LCD screen.

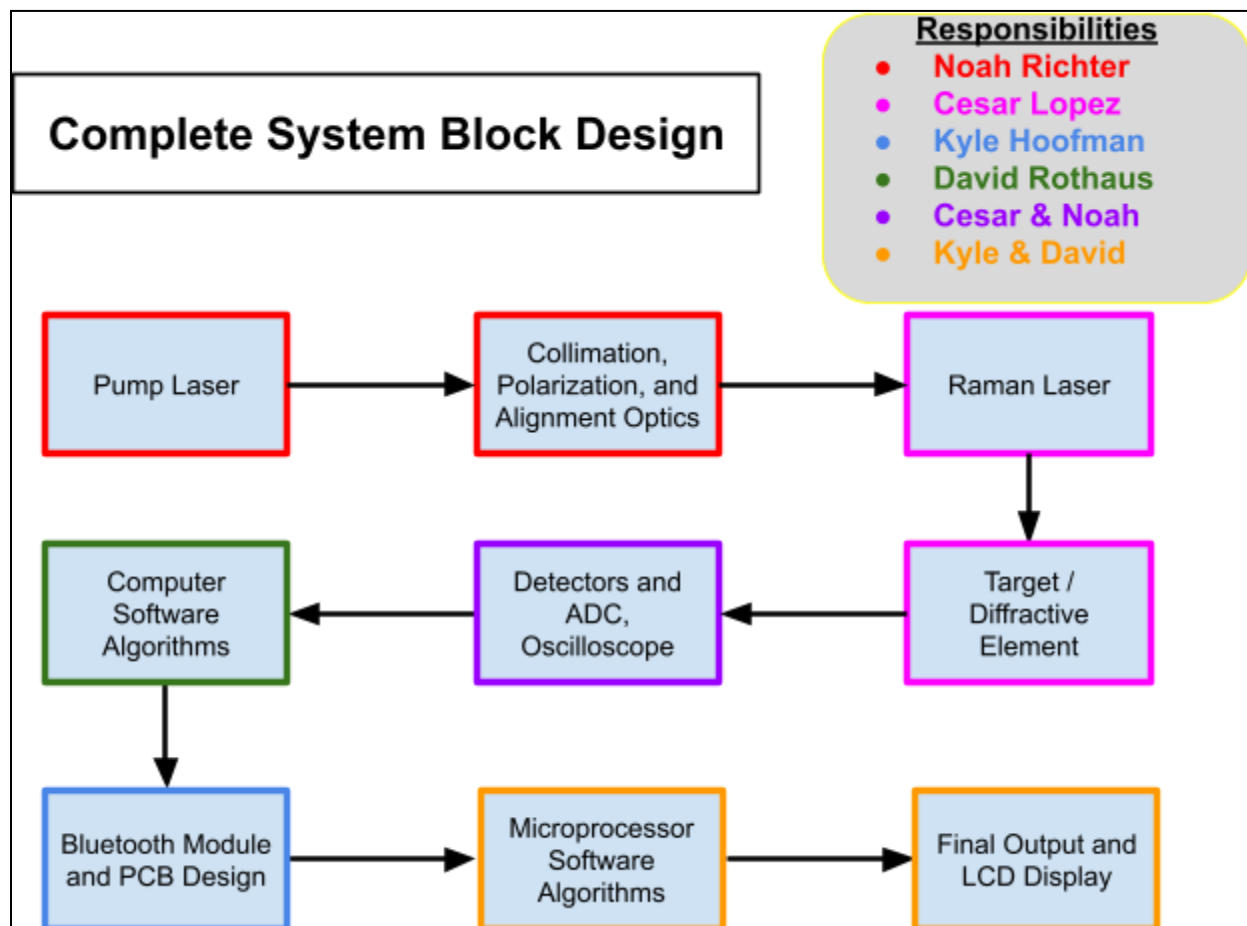

Fig. 2: Complete System Block Diagram

The advantage and novelty of our system is that it is very simple and straightforward, not requiring the use of dispersive optics and cavities. To do this, we take advantage of

the Raman gain of a silica fiber to produce wavelengths of up to four Stokes orders. By using their unique shape in time to tell them apart, it makes it possible to use a single detector. This detects the beam envelope and the electrical signal produced by the detector in the time domain is shown in the oscilloscope. Having gone through a calibration stage, the envelope shown in the oscilloscope will be post-processed in Matlab, where an artificial dispersion can be induced if needed. Then, by looking at the amplitudes of the waves in time, and knowing which wavelength each amplitude corresponds to, due to their shape in time, then the spectral reflectivity can be obtained. This information will then be sent via bluetooth to the electrical system, where it will be displayed for the user; the information sent will include the spectral reflectivity, the object detected, and possibly the range.

For the sake of simplicity, the flow of the overall system goes as follows:

Pump laser -> Raman laser -> Object -> Detector/Digitizer -> Computer -> Matlab -> Bluetooth module -> I2C bus -> ATmega328p-pu Microprocessor -> I2C bus -> LCD.

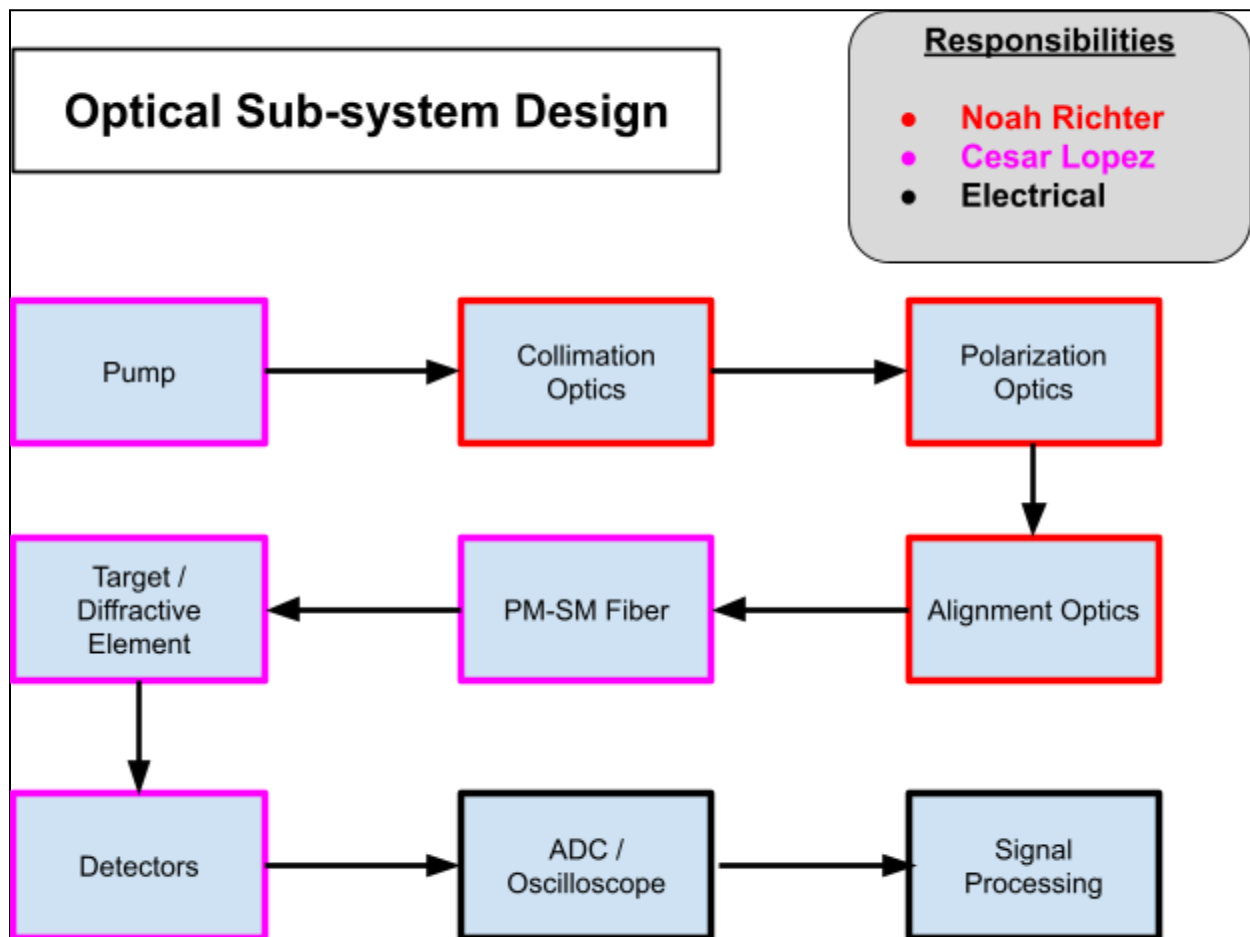

Fig. 3: Optical design block diagram

The figure above represents the main optical design architecture that Cesar Lopez-Zelaya and Noah Richter will be working on. It all starts with the pump laser, which is a diode-pumped Yb-doped fiber (not really specified, but more than likely) that has a lasing wavelength of 1064nm. This device is capable of delivering high repetition rates that range from 20KHz to 750KHz, pulse widths of 3ns to 5ns, and peak powers up to 25KW. Following this system is the alignment and polarization optics. The pump laser is capable of outputting linearly polarized light, but additional control is needed due to the Raman fiber being polarization-maintaining. Two silvered mirrors are used to control the path of the laser beam from the pump to the PM-SM fiber. The reason why two mirrors are used is because of the degree of alignment that they provide. The first mirror is used to precisely send the laser to a specific spot in the second mirror. The second mirror is used to aim the laser at the PM-SM fiber. Note that in between the two mirrors, polarization optics will be in place (these might actually end up going after the mirrors rather than in between). The first of these optics will be a polarizer. Depending on the polarization state of the pump laser, the polarizer can be rotated and aligned correctly to control the amount of power that comes out of it. The point is that when the polarizer and the polarization of the pump are orthogonal, the output will be essentially zero, according to the law of Malus.

Following these devices, which were primarily for alignment and power control, there will be a half-wave plate present. Before proceeding, it's important to mention that the pump will come with a collimation, polarization, and isolation package. These packages ensure that the light from the laser is not diverging greatly, is linearly polarized, and does not back reflect into the pump, which would damage it. Continuing with the parts, the half-wave plate is used for controlling the polarization direction of the light. In comparison to the polarizer, the half-wave plate does not attenuate the light. What it does is that when light of a certain polarization goes through it, it rotates the polarization of that light to a specific direction. This is extremely useful, as it will be what controls the direction of the polarization of light going into the fiber.

This brings the next set of components, the coupling stage and the fiber itself. The coupling stage is used to precisely align the fiber with the incoming pump laser pulses. Using a 20x objective to achieve a small spot-size, the PM-SM fiber will be placed in front of this objective, and by aligning the pump's polarization with the slow axis, light should be effectively coupled into the PM-SM fiber. Note, that the fiber will have a coreless endcap attached to it. This endcap will ensure that if the pump beam is too powerful, it will not burn the surface of the fiber. Thus, helping us save time and cost because when the fiber is burnt, cleaving and replacement of the fiber ends must be done. This is a semi-laborious task and should be done as little as possible since every time the fiber is cleaved, a portion of it goes to waste, which adds up over time.

As it was explained before, the PM-SM fiber is a regular optical fiber with a silica core and two stress rods to increase the birefringence of the material. However, when this fiber is pumped by an intense laser beam, it will spontaneously emit light at different frequencies (spontaneous Raman) due to the amorphous nature of the glass. Some of these frequencies will experience a higher optical gain than others, making it possible for photons of a frequency with higher gain to induce a transition from a higher state of the same energy. Thus beginning the process of stimulated emission, but through stimulated Raman scattering (SRS). Note, that this is not an optical parametric process since light directly interacts with the medium, transferring some energy into it to obtain Raman emission via molecular vibrations. This can also be understood because SRS is the inelastic scattering of photons by matter (matter causes the photons to inelastically scatter, transferring some energy to the medium, thus changing the quantum state). Where in inelastic scattering, for energy to be conserved, it is known that it is transferred to the medium (this can be understood more by looking at a Stokes emission diagram for Raman scattering, included below). Since SRS is a third-order nonlinear process, it requires an additional photon to occur. This photon comes from the spontaneous Stokes wave. Essentially what happens is that a pump photon is absorbed by a molecule, there is a probability for this molecule to absorb some of its energy to make a transition to an excited vibrational state, and the energy left over is emitted as a lower frequency (or energy) Stokes wave. Thus this process needs to transfer energy to the medium. Then, the Stokes wave acts as a seed with the pump, and together the pump excites more molecules and the Stokes waves stimulate transitions. This then starts the process of coherent and stimulated Raman scattering.

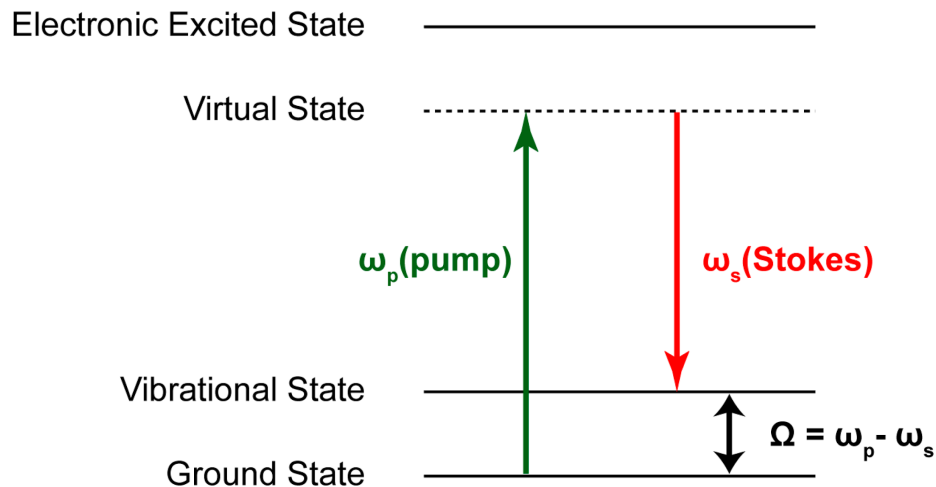

Fig. 4: Diagram showing the non-parametric inelastic process of SRS. It is inelastic because energy is transferred to the medium.

Following the Raman fiber is the next part of the setup which is a target. Depending on the stage of the project, this target can be a grating or an actual object, like a leaf for example. During the calibration stage, a grating will be used because the wavelengths

will need to be separated individually in space to capture them individually with the oscilloscope and record them for post processing. This will need to be done with all achievable Stokes orders, which will diffract at different angles. Longer wavelengths will diffract more than shorter wavelengths because they will be more comparable to the size of the grating. In the post-processing side of things, these waveforms of individual wavelengths will be recorded and then added up together to form the envelope, which is what actually comes out of the Raman fiber. When using a target, instead of dispersing the wavelengths and separating them, they will all come together and that's where the built envelope comes into play. Even though what will be detected from the target is an envelope, its relative intensity peaks, which correspond to different wavelengths, will be juxtaposed and analyzed.

This leads to the final part of the laser system design; the detectors and oscilloscope. At least two InGaAs high-speed detectors will be used for collecting data during calibration. During the actual application, only one will be needed since the post processing will be done separately. These detectors will be coupled to multi-mode fibers that will carry the optical signal to them, and BNC cables will be used to transmit the electrical signals they produce, to the oscilloscope. Data will then be visualized there and a snapshot will be taken and loaded onto a post-processing device for analysis.

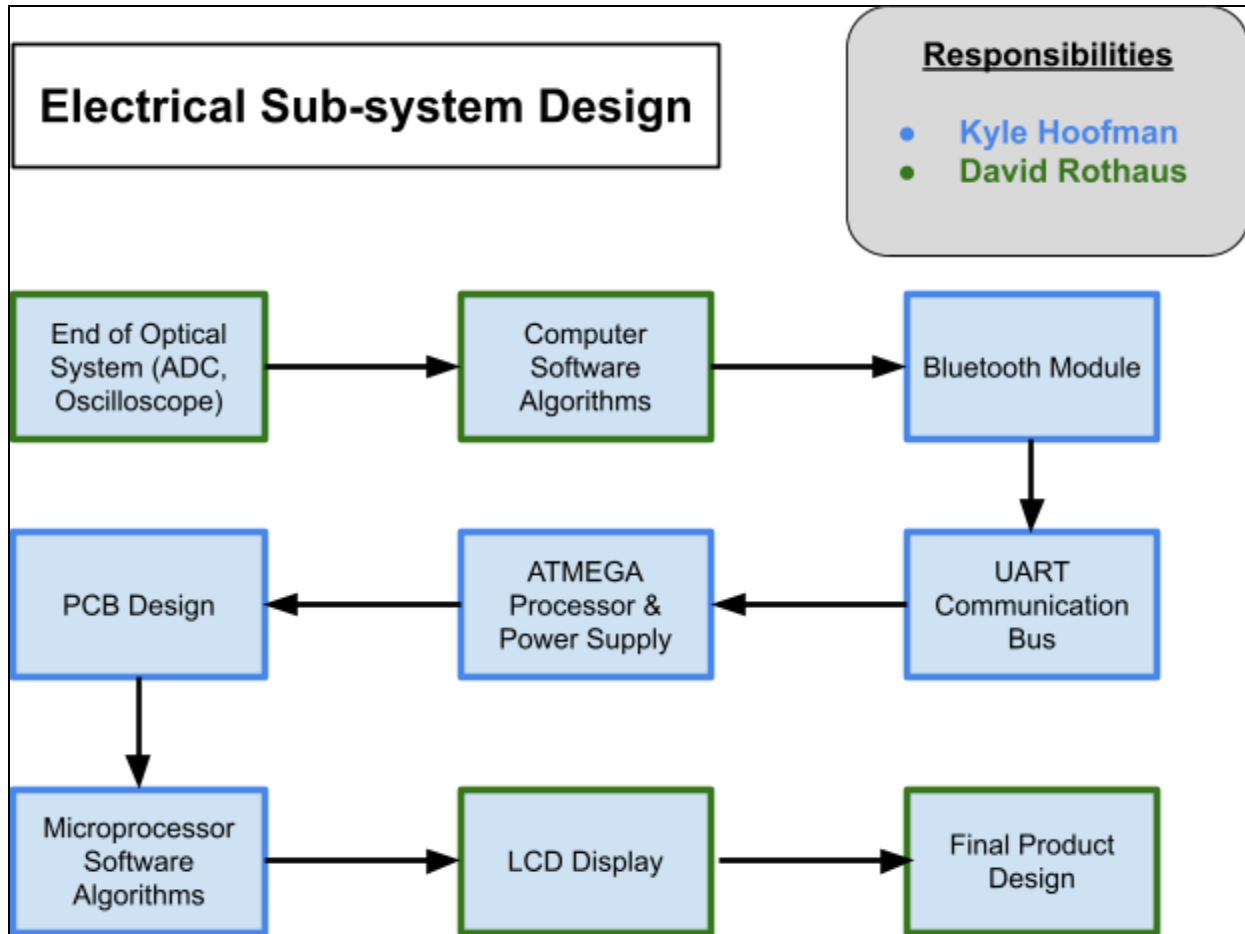

Fig. 5: Electrical Sub-system Design

The electrical sub-system will be divided among the two electrical engineers of the project, and the work is evenly divided among both. In order to ensure that the work is equal, it is essential to list out the separate components of the design process in order to assign work before it begins. Essentially, it would be impossible to subdivide the work fairly among all members without knowing what needs to be done beforehand, otherwise some members will end up taking on a larger portion of the project than intended. The electrical components of this project begin at the end of the optics portion, where the oscilloscope has received the signals. From there, software algorithms need to be written and hardware components need to be designed before the final product can be fitted in a convenient package for the end user. There are multiple parts within each of these steps, but below is a brief overview to understand why and how the work was uniformly divided, specifically for the electrical engineering portion of the project, as well as some quick insight into how the design process. Each member of the group possesses their unique strengths and weaknesses, and emphasizing the importance of sharing yet splitting up the work to play to these strengths is what makes a team so powerful.

The initial portion of the electrical system is the oscilloscope, which is the final optical portion of the project, and the method used to acquire a signal from our scattered laser after hitting the object in question. This portion will be worked on by both electrical and photonics members of the group, as it is the interface between each. This means that it contains elements of both the sides of the project, and an understanding is needed in order to create further steps. The photonics member will be able to set up the oscilloscope within the optical system, while the electrical member interprets the data from it and continues to work with that data for the entirety of the remaining project. The first step in interpreting this data is the software algorithms on the computer. These algorithms will take a large number of points directly from the oscilloscope of the Raman scattering waveform in the time domain and interpret it to create an output of what the object is. Information is included below in section 5.11 on software design which describes in greater detail the specific software, flowchart, and design choices behind the program, however, in short summary, it takes a large set of data points from the oscilloscope and outputs exactly what the object is as well as its distance.

The next major portion of the electrical engineering portion is the electronic design, which begins with the bluetooth module. This takes the output from the computer and sends the data to the circuit board through this module. Since this is the first location that the data will be sent after the computer in order to be processed by the microprocessor, it follows the software algorithms used to interpret data. While most of the design process for this section is also software, it will be used to program the chip and computer to communicate using the bluetooth module, rather than mathematically deciphering the data. Next, there needs to be a way for the bluetooth module itself to send data to the microcontroller and vice versa, which is the UART bus. More details on why this specific protocol was selected are included in section 3.4.4, but this program will simply allow the bluetooth module to be soldered on to the board and communicate with the processor in a simple and easy to implement method. This serial communication protocol will be used elsewhere on the project, though its implementation will be extremely similar. Since this is the next step in the sub-system that the data will travel, its implementation begins at this point. Next, the data will need to travel to the microprocessor itself, known as the ATMEL ATmega328, and the basis of all other programs, protocols, and design within the electrical portion of the project starting from the bluetooth module. While this portion of the design process is located in the dead center of the flowchart, it was the first portion of the entire sub-system worked on. This is because all the other portions rely on this processor. Choosing and implementing the microprocessor before working with any other portion of the project makes the most sense and is ideal. Now the rest of the printed circuit board (PCB) can be designed. This involves creating through-holes and mounting points for the bluetooth module and LCD display, wiring the power jack and timing crystal, all done within EAGLE CAD software. All components need to be selected before creating the circuit board; however, software testing can not begin until the board is printed (or at

the least, all the components have been ordered and can be tested separately.) Next, the processor will take the data from the UART bus and process it to create a more useful output before it is sent out to the LCD display for the viewer to understand the data. The LCD display will also communicate with the processor using the I2C serial communication protocol as opposed to the bluetooth module. I2C is also a simple to work with serial communication protocol.

The last portion of the project is only possible once the preceding portions have been completed, and that is finalizing the project in a simple to understand and easy to use product for the user. This means soldering the components together, rather than having the parts disconnected on the testing bench. It also includes packaging the product into a single, small, hand-held remote so the user can wirelessly use the data that initially started at the oscilloscope. At this point, the electrical engineering portion of the project is complete. Since most of this design relies on the completion of the optical portions of the project, this concludes the design process of the project.

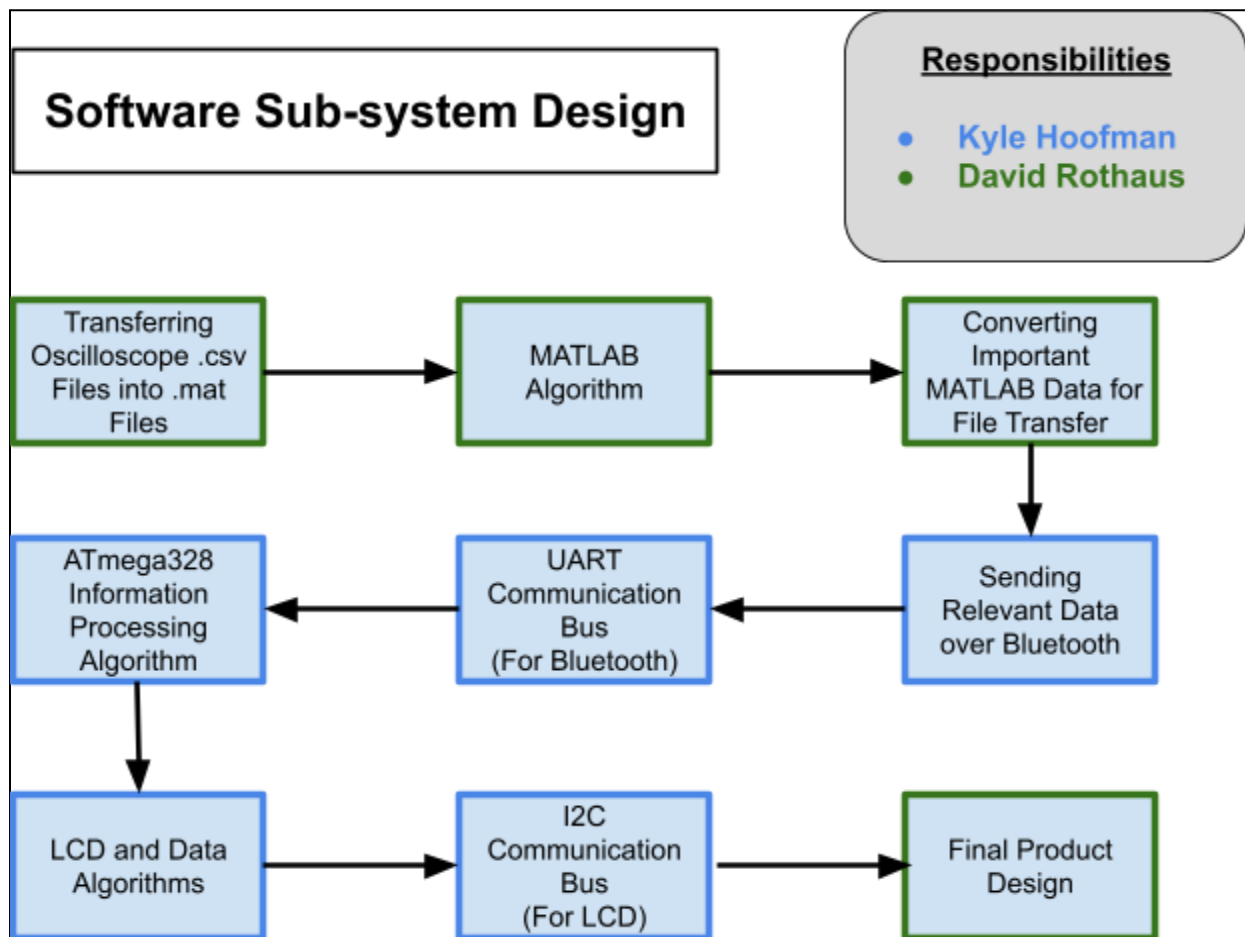

Fig. 6: Software Sub-system Design

The software components of the project will also be covered by the electrical engineering students. Just like with the electronic components, creating a flowchart of the different stages of software development is important in order to get a visual representation of what needs to be completed. This also allows the work to be divided equally ahead of its creation in order to ensure equal work between all group members. There are two main portions of that the software will follow: the computer will be used to process data from an oscilloscope in MATLAB and the code used for the microcontroller to properly display the necessary data. Most of the software testing will occur at home, using UCF Apps to remotely control a school computer and use MATLAB. The algorithms used on the electronic hardware will also be tested mostly at home, since it only requires a simple hardware setup with minimal equipment. Due to Coronavirus placing restrictions on meeting on campus, it is ideal to work from home whenever possible. However, especially as the project reaches its later stages, testing will need to occur in either the Senior Design Laboratory in Engineering 1 since the electronics will have been nearly completed or finished at this point and at-home equipment will not be adequate.

The first step in software design in getting the project to function will be transferring files from the oscilloscope to a format MATLAB can easily read and interpret. The oscilloscope will output the files in .csv format. The .csv format stands for comma-separated values, and essentially is just a very long list of all the data points captured by the oscilloscope all separated by a comma. While this is a very simple file, these should be reformatted into the .mat file type, a proprietary extension with MATLAB formatted data. This is important as the data within these files can be changed directly within MATLAB whether or not they are loaded into memory. After the data has been transferred into MATLAB, it will go through its algorithms to process the data, output graphs, and information that is necessary.

The next step is the algorithm that will be used to actually interpret this data. While the specifics of how the program is created and why certain functions were selected for use, the basic idea is to interpret the very large amount of data from the waveform of the Raman scattering and illustrate it on a time-domain graph, with amplitude on the vertical axis. Furthermore, the data is processed to determine other metrics such as Signal-to-Noise Ratio (SNR), Normalized Root Mean Square Error (NRMSE), and Induced Dispersion (ID). More information on the definitions and importance of these terms is included in section 5.11. This is where the bulk of the important calculations for this project occur.

Next, the data from MATLAB needs to be converted back to another file format. Since the important information such as object type and distance needs to be transferred through Bluetooth to the microcontroller yet the processor cannot understand the .mat file type. Another algorithm will need to be created that will take the most important

data from MATLAB and copy it into specific variables. These variables will be able to transfer over the Bluetooth connection easily, as the UART connection would not reasonably accommodate the large amount of data that is output from MATLAB directly. For example, if we want the object type, we can initialize a new variable that takes the values from MATLAB and processes the waveforms to output exactly what this object is, within a certain margin of error. The same can be done for our stretch goals, such as the distance. The waveform will also have this information and as long as the algorithm can be created, the process of converting the file back to a type readable by the ATmega328 will be identical. This data will be sent over Bluetooth using the Bluetooth module soldered to the printed circuit board. At this point, the software is now entirely related to the electronic design and the computer will no longer be used from this point forward (unless the program is reset and run again).

Now that the essential information has made its way to the Bluetooth module, it needs to make its way to the microprocessor. To do this, the UART serial protocol has been decided as the best method to send information back and forth between the ATmega328 and the Bluetooth module. This is an effective method that is fast enough for our purposes without being unnecessarily complicated, making electronic implementation fairly straightforward. In the same vein, the software will not be more than a few lines of code in order to get the UART communications up and running; nonetheless, it is an essential part of the process in transferring the data from the oscilloscope output to the liquid crystal display (LCD) in the software flow. At this point, the data has reached the ATmega328 microprocessor and is nearing its final stages of the software sub-system.

From this point, the main portion of the microcontroller's code will take the data from the Bluetooth module and interpret it. This means identifying the different variables and how to output them, and how they are going to be displayed on the LCD. There will also be LEDs implemented either directly on the board or soldered on, and code here will force those LEDs to turn on or off at the appropriate times. The embedded system will also need to utilize the crystal for ensuring the proper clock timings and initialize any other variables. These important, yet unseen, components of the circuit are essential and are vital to the success of the project. At this stage the most vital information is now ready to be sent out through an I2C communication bus. This time, however, the microprocessor will communicate with the 20x4 LCD to send the data to output and the algorithm on how to exactly display it in order to create a user-friendly experiment.

The final portion of the project, "final product design", is the closing element of the software flowchart. At this point, the project works as intended, but may need some tweaking to make it as easy to use and understand as possible. This means adding LEDs that turn on and off at appropriate and easy-to-understand timings, ensuring the

LCD outputs a display that is easy to read and understand, making sure the data is as precise as possible, and testing with multiple objects to ensure its functionality. Once all of this is working exactly as desired, there is yet more work to be done in order to improve the functionality of the device further. This is the implementation of our stretch goals. The most notable of these would be creating a distance meter from our existing object detector. This would require modifying all of the software mentioned earlier. The MATLAB code would need to have new algorithms to comprehend the data it receives and produce the distance from the laser and this would also need to be converted into a file format that the microprocessor can understand. Next, the LCD would need to be able to display this, if possible. If we have reached this point, we have gone well beyond what is required to complete the software flowchart and create a working sub-system.

3. Research and Part Selection

Some similar projects have been completed in the past, and their studies are beneficial in our design process. Much of it is research, whose scientific theories will be applied to our project in order to complete our objectives. By learning about relevant technologies, a greater understanding of Raman scattering is established, and why this technology is selected for this project. Furthermore, since research has been completed on these topics, it makes it possible to take advantage of its various properties to solve a given problem related to photonics and electrical engineering.

3.1 Technology Comparison

Several research groups have tried to achieve and show that devices like the one that we propose, work. Starting with Power and Davis, who used K-means, K-nearest neighbor, and maximum likelihood classifiers with multispectral LADAR scene data to accurately identify objects within a scene [1]. For reference, K-means and the like is a way to group, or cluster, a set of data for easy analysis and post-processing. Then, Gong et al. used a support vector machine to demonstrate higher classification accuracy of several different objects with a multispectral LiDAR versus a single wavelength version [2]. The following image is of the DWEL dual wavelength laser system, source <https://www.umb.edu/spectralmass/lidar/dwel>.



Fig. 7: DWEL dual wavelength laser.

Following these research efforts, the dual-wavelength (1064nm and 1548nm) Echidna LiDAR (DWEL), a full waveform system, can distinguish leaves from tree trunks with a 150MHz bandwidth and 2GHz sample rate corresponding to a 5 ns laser pulse width. Douglas et al. mentions that the two digitizers are the largest energy consumers of the system [3]. It's important to mention that similar to our project, the most expensive and bulky piece of equipment will be the detector-digitizer setup, which will be an oscilloscope. We often considered building our own detector-digitizer system but because of the nature of our project, it is too complicated and falls outside of the scope of our budget and time. Especially since we need a bandwidth that is over 2GHz and oscilloscopes that are at that range and beyond tend to be in the \$100,000 range.

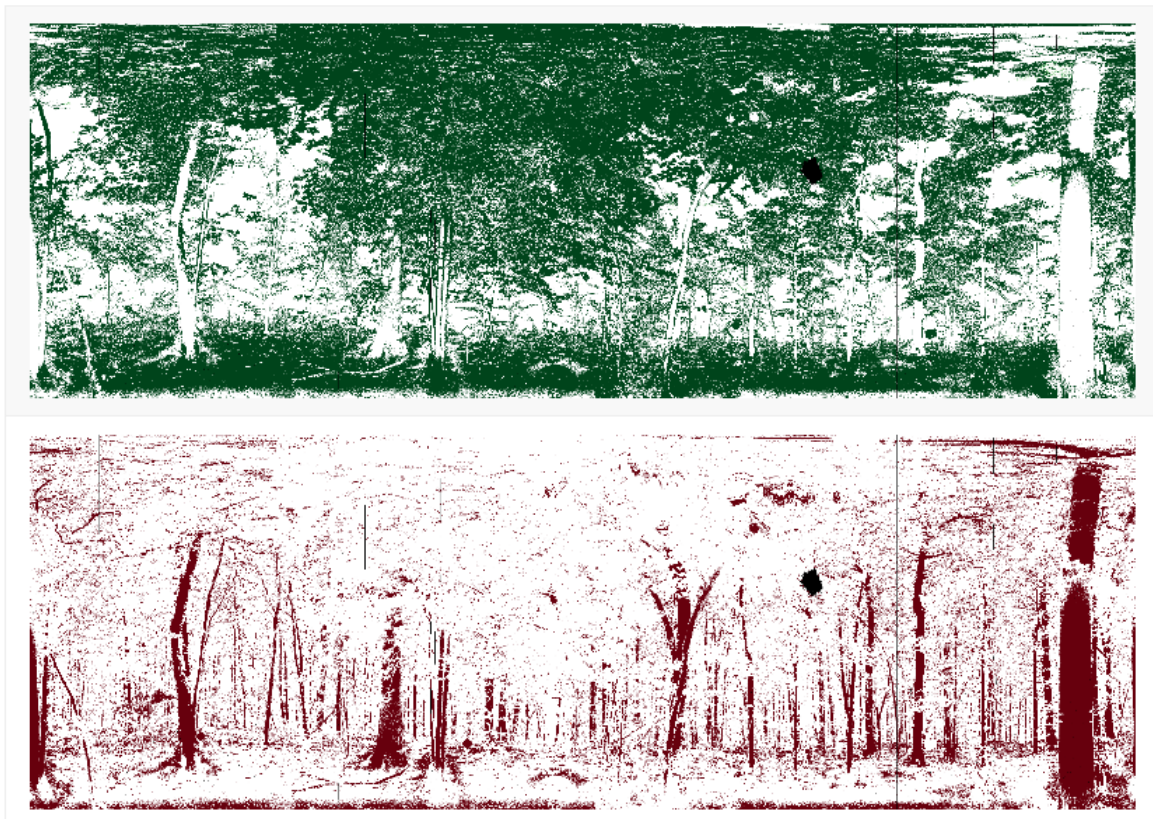

Fig. 8: Echidna LiDAR images showing greater absorption of leaves at SWIR wavelengths (bottom) versus a higher density of detected reflections (top) because NIR light is not absorbed as much by leaves. Note: our project WILL NOT be able to capture these images.

Danson et al. presented the Sanford Advanced Laser Canopy Analyzer (SALCA), also full waveform, which uses two wavelengths (1063nm and 1545nm) to measure characteristics of forest canopies [4]. The commercially available Optech Titan uses 3 wavelengths (532nm, 1064nm, and 1550nm), however each wavelength is pointed at a different angle, not co-boresighted, requiring post processing to correlate geo-located

points with multispectral data [5]. A common theme in all of these systems is that using multiple wavelengths improves the detection capability of the LADAR/LiDAR system itself. The main issue, however, is that these systems are restricted by using just two or three wavelengths which must typically be separated in space. This requires bulky and more expensive components. The difference between what we are proposing (and that Ausley, Keyser, and Martin did) is that we will be working in the time domain to be able to distinguish the different wavelengths. This eliminates the need of big bulky spatially dispersive optics and simplifies the working of these kinds of systems by a lot. The following figure is of the Optech Titan multispectral laser, source <http://www.teledyneoptech.com>.



Fig. 9: Optech titan multispectral laser.

One particularly relevant project is Ausley, Keyser, and Martin, who used LADAR-based sensors to identify an object from a background based on its Raman spectral reflectivity, using the unique waveforms of an object's Raman scattering to identify it within its surrounding. Temporal multiplexing is used, which is one of the design's advantages. [6] Temporal multiplexing uses a laser operating within multiple regions of the electromagnetic spectrum, called a "multispectral laser", using a singular detector and digitizer. This hardware will be discussed in further detail later in the document; however, for the purposes of this explanation, all that needs to be known is that a single transmitter and receiver are necessary in order to identify an object. The figure above displays a visualization. Note the single Raman laser pump with a single detector. The data from the digitizer is synthesized by separating the waveform in time into its individual wavelengths in the frequency domain. More details are provided later in the document on the theory and software used to effectively do this. Notably, a long fiber spreads the wavelengths to a point where frequencies are no longer overlapping. Of course, a long fiber is impractical in most real-world scenarios, both for size and cost. This means that the detector and digitizer combination will need to be effective

even with the high signal-to-noise ratio present within a signal that has its frequencies combined within time, exploring the possibility of this new architecture when compared with a long fiber to separate the light. Normally, in something such as Raman spectroscopy, a detector array would be used to separate the signal in time. This is extremely relevant to our project where we will also be classifying objects using Raman scattering. However, we will be using silica fiber rather than hydrogen, as it is more accessible and easier to use in terms of its handleability when in the lab. This comes at the cost of a slightly more complex waveform noticed by the detector. The following figure shows what the Ausley et al. laser system does, source [6].

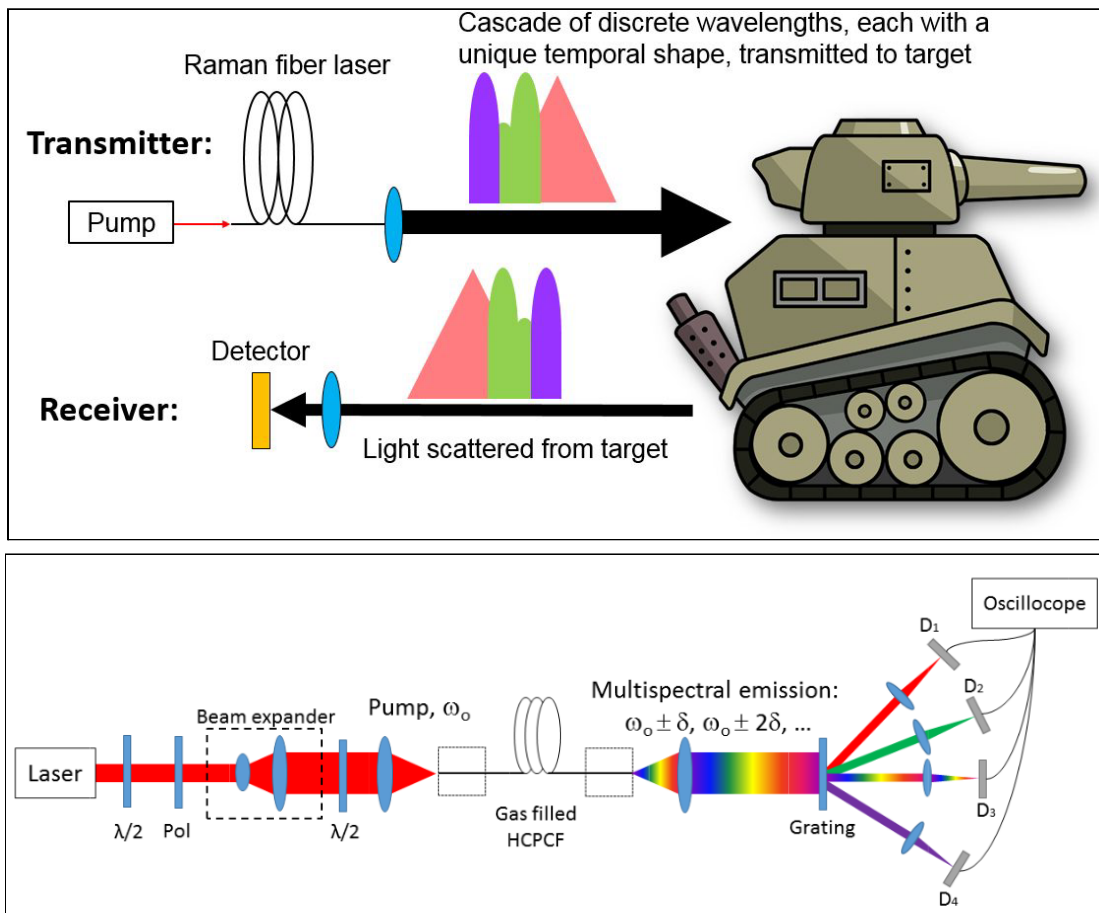

Fig. 10: Temporally multiplexed LADAR, used to identify an object (top). Laser setup used by Ausley et al. to obtain a multispectral output and characterize it with an oscilloscope (bottom) to then use it for what is shown at the top.

Cohen and Lin found the spectral emission curve for a single mode silica fiber laser, which is what we plan to use. While we know that the object will emit its Raman scatter, it is important to not forget that the fiber optics themselves will also affect the output from the laser. Knowing the silica fiber's power at a given wavelength will be

crucial in software calculations. If not, the output may resemble an entirely different object from what is actually in front of the laser, causing confusion. To avoid this, the software will account for this and subtract it from the final output. Using this information in our signal processing calculations will prove invaluable while creating and understanding a first and second order Stokes waves.

The most closely tied optical component to this is the Raman spectrometer. Which is a device for characterizing materials in a similar way, but requires the use of cavities, works only in short range and typically only works with small samples. This type of device is typically used for Raman spectroscopy. Raman Spectroscopy can provide invaluable data related to an object's properties through the interaction of light. "Raman Spectroscopy is a non-destructive chemical analysis technique which provides detailed information about chemical structure, phase and polymorphy, crystallinity and molecular interactions. It is based upon the interaction of light with the chemical bonds within a material." [7] As light touches an object's chemical bonds, most of the byproduct light waves are identical to the source laser, known as Rayleigh Scatter, which is not useful for our purposes. However, a significantly smaller portion (less than a millionth of the light particles) will be reflected in a unique way depending on the structure. These wavelengths are known as Raman Scatter, and the basis of our project. Once a sample has been hit with a laser beam, a notch filter will be used to eliminate frequencies related to the original laser source, leaving only the reflected Raman scattering. Generally this means that the sample will reflect the light waves rather than absorb them.

Numerous applications of Raman spectroscopy are possible, such as detecting structure, identity, contamination, impurity, or intrinsic stress. Notably, our project will be using its structure and identity detecting properties to distinguish a material. Some examples of materials that are fantastic for analysis with Raman spectroscopy are: pure chemicals, biological materials, solids, and gases (among many others), useful in chemistry, geology, biology, and semiconductors. However, there is a weakness; as it is not suitable for pure metals and alloys. This is because metals are unable to show a change in polarization, and atoms are unable to vibrate when they are excited by a light source like in most other materials. For the purposes of our project, we will not be attempting to analyze these materials that are unsuitable. In general, of the materials that do work, gases are more difficult to analyze because the concentration of molecules is very low and analysis can be difficult; however, it can be done.

The Raman spectrum itself can be obtained from the unique wavelengths that are projected off the chemical bonds. While the detailed physics are generally out of the scope of this project, it is important to note why these wavelengths arise. Symmetric stretches, vibrations with many bonds, and heavy atom vibrations display as higher intensity wavelengths. The higher energy (shorter wavelength) frequencies are

scattered on what is known as the anti-Stokes line and lower energy (longer wavelength) frequencies are scattered on the Stokes line. When analyzing, it is much simpler to utilize the highest intensity Stokes lines. Simply viewing this spike in the graph of the frequency spectrum can provide invaluable data. The position of the peaks themselves tell what the material is. This is the main purpose of our project; however there are numerous other properties to be analyzed from this frequency graph. Shifting the frequency of the peak shows material stress, the narrowness of the peak shows the crystallinity, and the overall height (intensity) presents the concentration of the material.

A Raman spectroscope is configured using a light source (laser) that is passed through a bandpass filter to remove unwanted frequencies from the laser, keeping the initial light source within as narrow a frequency band as possible. It is then reflected off the desired object, and filtered again. This time, the filter is a band-reject filter that removes all the frequencies of the laser. Recall that the laser's frequencies are Rayleigh scattered, and removing them will leave the Raman scatter. At this stage, all that is left is the Raman light from the object. The next step is to pass this Raman light into a spectrometer, which will divide the light into its unique wavelengths. This can be synthesized back into a frequency graph with the Raman wavelengths, and analyzed through various different methods. One of the largest advantages of Raman spectrosopes is a simple analyzer, such as the one described above, can be expanded for a plethora of uses. It can be done in a relatively easy fashion when compared to other technologies used to analyze materials. Even still, there are more advantages, such as: no preparation necessary on the material, liquids and gases can be ascertained with relative ease, long fiber optics allow use at a distance, the chemical structures have patterns shared between almost all chemical bonds, allowing the user to identify a new material's chemical structure. While the laser and setup are generally expensive, the case and holder are built in a simple and inexpensive way.

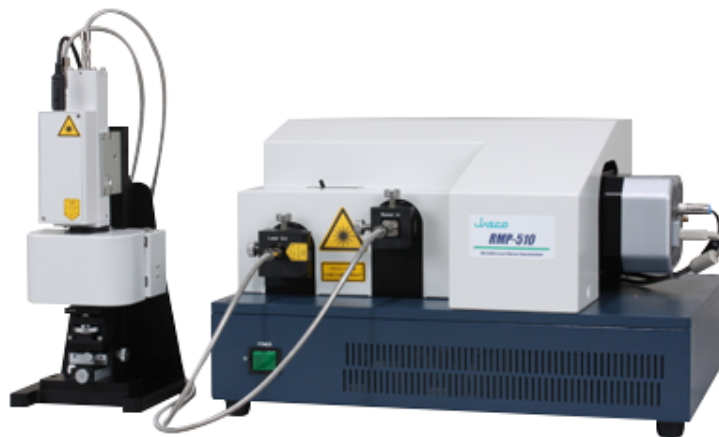

Fig. 11: RMP-510 Probe Raman Spectrometer. Probe is the type of device used to place the sample in, to non-intrusively pump it with a laser and collect the Stokes and/or anti-Stokes frequencies.

In general, Raman spectroscopy can be used on such a wide variety of objects that it makes an extremely practical method of detecting the properties of a material, since “Raman spectroscopy can be used for both qualitative and quantitative applications” [4]. In a qualitative sense, the unique spectra are able to distinguish a sample, which is extremely useful in our circumstances, where this is intended to be used to identify an object’s name. However, for more scientific purposes, qualitative analysis proves useful. As discussed before, the crystallinity, stress, concentration, and specific chemical structure are shown from the frequency response of the Raman scatter and stored into an online database for other researchers and engineers to access when necessary.

A chemist would find a great use for observing a unique chemical structure of an unknown or modified material, and a physicist could observe the rotational and vibrational states of a molecule. Electrical engineers could use this technology in semiconductor manufacturing to ensure correct doping of a semiconductor to provide expected current flow, since the height of the peak indicates the concentration of a positive or negative dopant and precisely creating the appropriate levels needed for a specific application. Photonics engineers could use Raman spectroscopy as an excellent method of discerning an object, such as what will be used with this project.

Another method of detection with a similar goal of identifying substances is Infrared Spectroscopy. While this can show a substance’s chemical structure using light waves, just like Raman spectroscopy, the method of doing so is entirely different. In fact, its methods of detection are almost exactly the opposite of Raman scattering. Most obviously is the usage of infrared; less obviously, the absorption is what is observed. As the infrared photons make impact with bonds of molecules, they vibrate as they absorb energy. However, this absorption only occurs at frequencies unique to each material. Instead of observing the strongest frequencies reflected off of a sample, as explained in Raman spectroscopy, infrared spectroscopy measures the strength of the output and notably shows peaks where the observed wavelengths are the weakest. The most optimal frequencies are from 19 to 120 THz with a corresponding wavelength range of 2.5 to 16 μm . This is because “Photon energies associated with this part of the infrared (from 1 to 15 kcal/mole) are not large enough to excite electrons, but may induce vibrational excitation of covalently bonded atoms and groups” [8], meaning that this range is perfect for achieving a desired spectrum from a substance.

While this method is effective in detecting a chemical’s structure in the same way Raman spectroscopy can, and both are a form of vibrational spectroscopy used to

fingerprint a species, our project will utilize Raman spectroscopy. For starters, infrared spectroscopy is unable to identify symmetrical molecules, making it less superior in terms of detection capabilities. Furthermore, the range of laser frequencies is smaller using infrared spectroscopy, as Raman allows the use of visible, near-infrared, and near-ultraviolet frequencies, rather than just a small portion of the infrared range. Possibly the most significant difference is Raman spectroscopy's ability to produce a large peak at the Stokes and anti-Stokes line, which is essential in the software calculations of our project. The other vital advantage is the lack of preparation required in Raman spectroscopy. Assuming both a Raman and infrared spectroscopy system are set up, Raman scattering occurs with almost any sample with no preparation required, whereas infrared requires elaborate preparation. This is important because it allows any unknown object in the real world to be detected at a moment's notice, important when the user is unable to access the sample (such as when using the laser from a distance). Yet another advantage of Raman spectroscopy is its ability to work through water. In fact, it works as well through water as it would through air or a vacuum, adding the possible use of detecting objects through or in water. The last major advantage of Raman spectroscopy is its speed, as an entire object can be observed as quickly as a second or less. The largest downside to Raman spectroscopy is cost, as these instruments are quite a bit more expensive when compared to infrared lasers and beams. Overall, Raman spectroscopy provides a better method in most cases, assuming the budget allows for such a setup to be created. This is the methodology behind choosing it for this project.

3.3 Strategic Optical Components

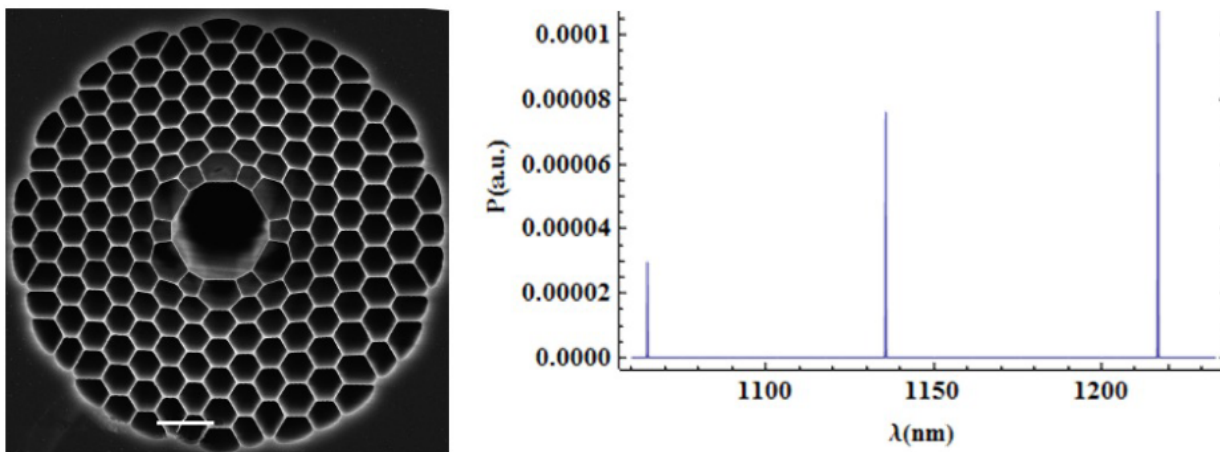

Fig. 12: Standard silica PBG fiber (left) and hydrogen emission lines (right).

The system being discussed, analyzed, and designed in this text has a primarily optical function. As discussed in the earlier sections of the text, there are several types of laser

devices. Some of these are gaseous, semiconductor, dye, solid-state, and fiber-based. Based on specifications and where this device could be deployed, low CSWaP is desired. Thus a lightweight and stable laser system must be built. This laser must also be multispectral by taking advantage of SRS. Narrowing down options, we decided to make a nonlinear fiber laser. At first, we considered the possibility of using a photonics bandgap (PBG) fiber to fill with hydrogen and take advantage of the neatly defined Raman emission lines. This version of the project, however, proved to be too difficult to do at UCF. First, there was no lab to use hydrogen in, and the way in which the system would have been set up would have been extremely difficult. The following figure shows the hydrogen SRS spectrum and a PBG fiber from Ausley et al.

Since SRS can occur in many media, we were not really worried about having to get a rare-earth doped fiber or medium. After some thinking, we decided to drop the gas idea, and go with conventional silica glass. This is an attractive idea because it exponentially decreases the difficulty of building the system and makes it more similar to what someone might actually take to the field. The following figure shows the SRS spectrum of a silica fiber, obtained from IEEE Journal of Quantum Electronics, 14(11), 855-859.

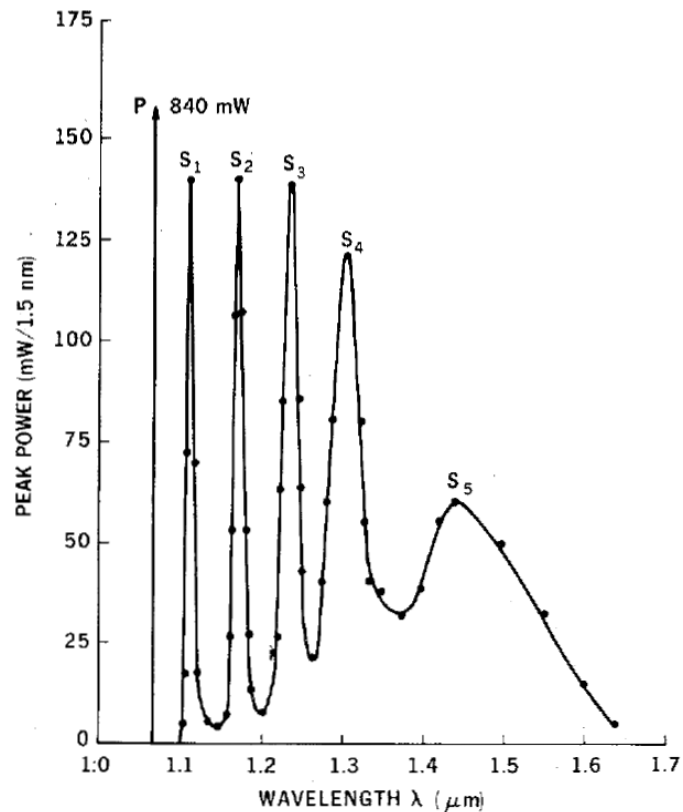

Fig. 13: Emission data of a multispectral single-mode silica fiber Raman laser.

First of all, the Raman lines of silica. These do not look as clearly defined as the hydrogen gas lines. This occurs because of the amorphous nature of the glass. By laser pumping the glass with a very strong laser, we actually make all of the molecules in the medium vibrate and a continuum of wavelengths is generated. This continuum of wavelengths has a span of about 40THz beyond the pump, towards the lower frequencies (deeper into the IR regime). As reported by Cohen et. al, in a fiber with similar properties to ours, they were able to observe light being generated up to the 5th Stokes order. This is really good, however there is one variable that we are going to have to fight with, which is the continuum still being present despite the 1st-4th Stokes being clearly visible. Unlike the neatly defined hydrogen lines, the continuum might introduce some noise into our signal analysis, so we might have to put an iris to filter out some of the weaker output still present between the Stokes waves.

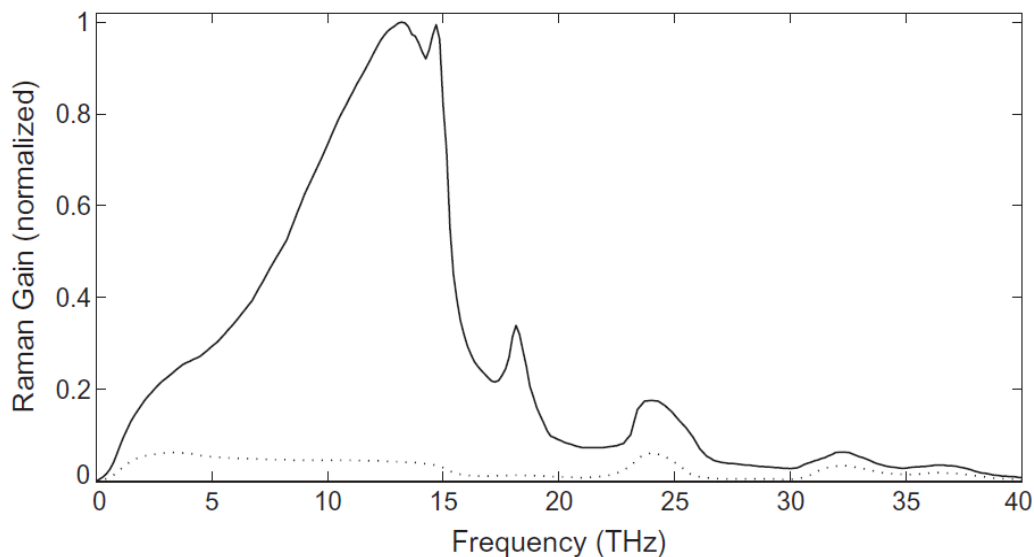

Fig. 14: Raman gain curve of silica glass as a function of frequency shift. All Stokes orders are expected to be about 13THz downshifted from each other.

Another method of avoiding this noise is to reduce the power that we are going to put through the silica fiber. By appropriately using the laser controller, the power sent into the Raman fiber can be controlled and enough can be sent in to just see the desired Stokes waves. It's important to note that we want to observe the 5th Stokes order, but don't think that it will be useful in detecting spectral reflectivities due to how broad it is. This broadening of the spectrum is caused by self-phase modulation. The following figure shows the Raman gain spectrum, obtained from [14].

SRS is heavily reliant on polarization. The polarization state of the pump and generated SRS light have to be co-polarized. Due to how light is generated within the fiber (starting with spontaneous Raman emission), one must ensure that the light that is generated remains in one polarization direction. For this, we have opted to use a $5.5\mu\text{m}$

core PM-SM fiber. The following image is the cross-section of a PM-SM fiber, obtained from FiberLabs Inc.

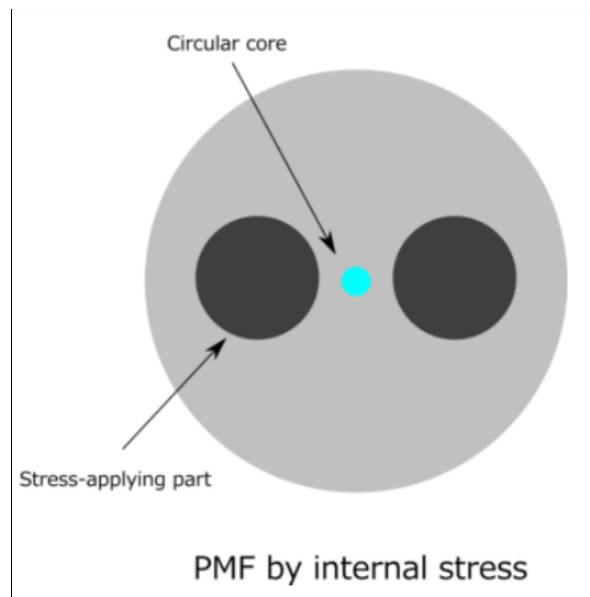

Fig. 15: Silica glass polarization maintaining fiber cross-section. This type of fiber will be the Raman gain medium and its polarization properties will minimize polarization scrambling.

This kind of optical fiber takes advantage of two stress rods located in a position transverse to the core. These stress rods introduce a higher birefringence in the core, making light travel in a linearly polarized fashion. It's important to mention that the reason why this happens is because the stress rods make it possible for the core to have two axes, a fast axis and a slow axis. Therefore, if we send in light through the slow axis of the fiber, we can ensure that most of the light will remain with that polarization mode and the gain will mostly happen there (preventing the power from one polarization mode from coupling into the other). This drastically reduces the threshold length required to achieve SRS, cutting down on cost and making the system a bit more simple and compact. This type of polarization behavior in a fiber is called polarization scrambling.

For informational purposes, the way in which light is guided in the fiber will be explained. Optical fibers consist of two parts, a core and a cladding. The core is the part responsible for carrying light and the cladding is usually a secondary piece of glass or dielectric material that surrounds the core. Technically speaking, the main purpose of the cladding is for it to be a lower refractive index medium than the core. When light goes from a medium of high refractive index, to a medium of lower index, there is a certain angle at which it will refract at 90 degrees with respect to the surface normal line in the lower index medium. The angle at which this happens is called the

critical angle. This angle is the maximum angle with respect to the core walls at which light can be guided. Any angle greater than this will leak out into the cladding of the fiber. The following figure shows different modes that exist in a cylindrical optical waveguide, obtained from [11].













Linearly polarized mode	Hybrid modes	Field distribution	Intensity distribution of E_z
LP ₀₁	HE ₁₁		
LP ₁₁	TE ₀₁		
	TM ₀₁		
	HE ₂₁		
LP ₂₁	EH ₁₁		
	HE ₃₁		

Fig. 16: Various mode patterns that can be excited within the core of a cylindrical optical waveguide.

From this basic principle, guided electromagnetic modes arise. These different modes can be excited in the fiber depending on the mode of the source of light being launched into the fiber or depending on the angle at which light enters the fiber. A mode is the spatial distribution of the electromagnetic field inside of the fiber. For higher-order modes, higher cladding induced loss is experienced due to these modes leaking out more into the cladding.

Another reason why we plan on using a PM-SM fiber is because only the fundamental mode is supported for the wavelength range that we are going to be working with, $1.064\mu\text{m} \leq \lambda \leq \approx 1.440\mu\text{m}$. The good thing about working with single-mode fibers, which only support the fundamental, or Gaussian mode, is that the intensity distribution is like that of a conventional laser mode with the highest intensity of light is in the center. This ensures that most of the power is in the fiber's core because the supported mode is the one with the lowest-order.

One of the most interesting things about this device is how we are going to make a laser out of a regular PM-SM fiber. To understand how this will be possible, we must briefly discuss the nonlinear response of a medium when excited by intense electromagnetic pulses. First of all, it is evident from Maxwell's equations that the

dipole moment per unit volume, or polarization, of a material depends on the strength of an applied optical electric field. Conventionally, this is given by $\vec{P}(t) = \epsilon_0 \chi^{(1)} \vec{E}$. In this linear equation, the proportionality constant χ is the material's electric susceptibility. Since we are dealing with nonlinear optics, the response of the material to the applied optical field is nonlinear. Therefore, this equation can be expanded into a power series, $\vec{P}(t) = \epsilon_0 \chi^{(1)} \vec{E}(t) + \epsilon_0 \chi^{(2)} \vec{E}^2 + \epsilon_0 \chi^{(3)} \vec{E}^3$. For an amorphous material like silica glass, $\chi^{(2)}$ is practically nonexistent due to its molecular structure, but $\chi^{(3)}$ is present and SRS is a third-order nonlinear process. Note that this amorphous nature of the glass is what makes it have such a wide Raman emission spectrum.

In a nutshell, SRS is the inelastic scattering of higher frequency pump photons by an optical medium in the nonlinear regime. For our PM-SM fiber to be a laser, it has to be capable of emitting coherent light. Since silica is not a laser gain medium, this has to be obtained by pumping the fiber by an intense pulse of light. To achieve this, AFRL has loaned us a 1064nm fiber laser from Lockheed Martin. This system has low jitter and will not create a noisy signal from the Raman fiber due to it having a small number of longitudinal modes.

This laser will be operated at a maximum peak power of 1kW, repetition rate of 20KHz, and pulses with temporal widths of 3ns. Having this laser go into the PM-SM fiber will make it so that when the input power is high, the fiber will start responding nonlinearly to the incident light. Due to the vibration of molecules, light will begin to be emitted by the fiber via spontaneous emission. This process is not coherent, but it's what is needed to get stimulated emission and the Stokes waves. With a strong input power, more photons will be scattered from within the fiber, generating more light, until the power is high enough and the amount of photons scattered within the fiber will begin stimulating the transition of energy states, which will emit more photons, this time with the same polarization and phase as the incident spontaneous photons. When this process of stimulated emission starts, the 1st coherent Stokes is generated from the Pump. Then, when the 1st Stokes is strong enough, it will generate the 2nd Stokes. This same process will repeat over and over until the final Stokes wave is weak. The cascading process will generate light at lower wavelengths, which will be used in the detection stage of the device.

3.4 Relevant Electrical Technologies

3.4.1 Relevant Project

The first relevant project [10] is very similar to what we want to do with displaying information directly from a device to the arduino to the LCD screen. In this project they use an HC-05 Bluetooth module, a 16x2 LCD display and some wires and connectors, along with an Arduino Uno. They use pre-sourced code and upload it to the arduino straight from the laptop. They then connect the LCD directly to the Arduino with the wires and connectors. Next they connect the HC-05 bluetooth module directly to the arduino using the 3.3V, the GND, the RX, and the TX pins. For the next step they pair the HC-05 bluetooth module to an android phone putting in the default passcode for the device as 1234. They then use an app on the app store to connect to the arduino and transfer information such as text from the keyboard directly to the arduino which then displays the text on the 16x2 LCD display. We can use this project as a good reference but there are some stark differences in that we will be creating our own software to transfer information from the device which in our case will be a computer, to the arduino which in our case will be our custom PCB microcontroller. Another difference is that they use the older HC-05 bluetooth module while we are going to use the HM-10. Although these two bluetooth controllers are similar in function.

Below we will talk about the different technologies on the electrical side that we have considered when deciding how to implement our ideas with the custom PCB microcontroller. We will talk mostly about the different methods of communication we will have and how they work between our devices. Furthermore, we will also be talking about how we will control our display.

3.4.2 Serial Communication Technologies

Serial communication is described as the process of sending data one bit at a time over a computer bus or communication channel, as opposed to parallel communication in which several bits are sent at a time to several parallel channels. This process is used on most computer networks because parallel communication would be costly and ineffective. An example of serial communication would be sending data from a microcontroller to an OLED screen as we plan to do in our project. Several different standardized serial communication methods exist today that define the methods for sending and receiving data. Some popular serial protocols include USB and ethernet. There are also the very common serial interfaces SPI and I²C.

These interfaces can be grouped into one of two groups: asynchronous and synchronous. An Asynchronous serial interface transfers data without an external clock. This method of transmission is great for embedded systems that need minimal use of wires and I/O pins. An example of asynchronous serial protocol would be UART. A synchronous serial interface always includes a clock signal so that all devices on the bus share a common clock. This promotes quick transfer of data, but has a requirement of an extra wire when communicating between devices. Some examples of

synchronous serial protocols would be I²C and SPI. When we consider these technologies and the way we want our devices to communicate between each other it is critical that we use a practical serial communication protocol. In our project we decided on external devices that use I²C to communicate, this is because it lowers the amount of pins and wires needed to connect to our microcontroller.

3.4.3 SPI

SPI which stands for Serial Peripheral Interface bus is a serial communication protocol common to many devices such as the SD card, RFID card readers, or 2.4GHz wireless transmitters and receivers. SPI has many benefits in that it can transfer data in a continuous stream with no interruption. To be specific there are no packets when dealing with SPI as compared to I²C and UART. SPI also allows devices to send and receive data at the same time. Devices that are using SPI communication have a controller-peripheral relationship. The controller is the controlling device which is usually a microcontroller while the peripheral is usually a sensor or a display. SPI systems usually have a single controller that controls more than one peripheral. The number of peripherals is limited by the load capacitance of the system.

SPI have four different lines that facilitate information:

- COPI(Controller Output/Peripheral Input): controller sends data to peripheral
- CIPO(Controller Input/Peripheral Output): controller sends data to peripheral
- SCK(Clock): the clock signal
- CS(Chip Select): this wire determines which peripheral to send data to



Fig. 17: Controller-Peripheral SPI configuration 1 to 1

First we will talk about COPI in which the controller sends data to the peripheral bit-by-bit. This data sent from the controller is sent with the most significant bit first most of the time. The peripheral can also send data back to the controller through the CIPO line. The data sent through this line most likely has the least significant bit first. The next important line is the clock. The clock synchronizes the output of the data from the controller to the peripheral's parsing of the output bits. Each clock cycle includes one bit of data transferred between the controller and the peripheral. This means that the speed at which data is transferred is determined by the clock frequency. SPI communication is therefore always initiated by the controller because the controller (the

microcontroller) generates the clock signal usually through an oscillating crystal. The clock signal can be modified by using clock polarity and clock phase. These two properties determine when bits are outputted and when they are sampled. Clock polarity is set by the controller to work on the rising or falling edge of the clock to output or sample a bit, while the clock phase is used to do the same but on the first or second edge of the clock cycle whether it is rising or falling.

The chip select line allows the controller to choose which peripheral it wants to by setting the chip select line to low voltage level. When the CS line is set to a high voltage level it is in a state of idle where it does not transmit any data. Multiple CS lines are used by controllers when working with many peripherals this allows the peripherals to be wired in parallel. There are two ways that a controller can work with multiple peripherals which is daisy chaining or wiring in parallel.

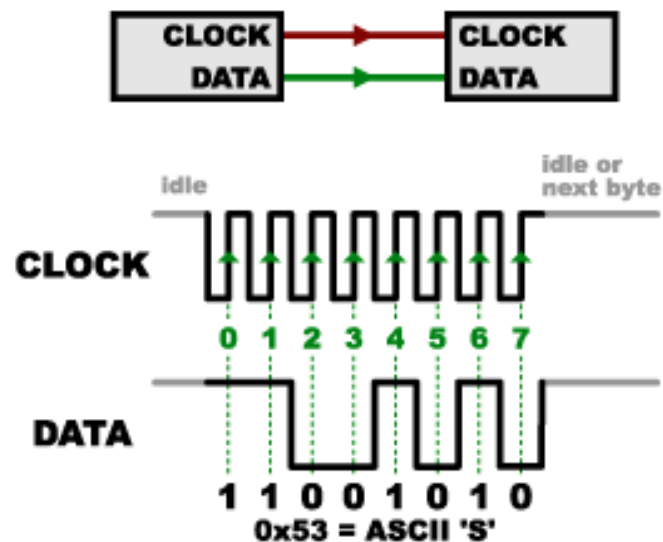

Fig. 18: clock signal using polarity to determine data sampling

Lastly the advantages of SPI are as follows: SPI is faster than asynchronous serial communication protocols, has no start and stop bits that limit continuous streaming of data. The peripheral addressing system is very simple when compared to other serial communication protocols such as I²C. SPI also has a high data transfer rate. The disadvantages of SPI are as follows: SPI requires a minimum of four lines as opposed to the two lines required of I²C and UART. SPI has no success checks when data is received like I²C has. SPI also only allows for a single controller that controls all communication meaning that peripherals cannot directly communicate with each other.

We will not be using SPI in our project because I2C has less wire requirements and is easier to implement in our project. Below is a diagram that shows all these lines working together to send data back and forth between the controller and the peripheral.

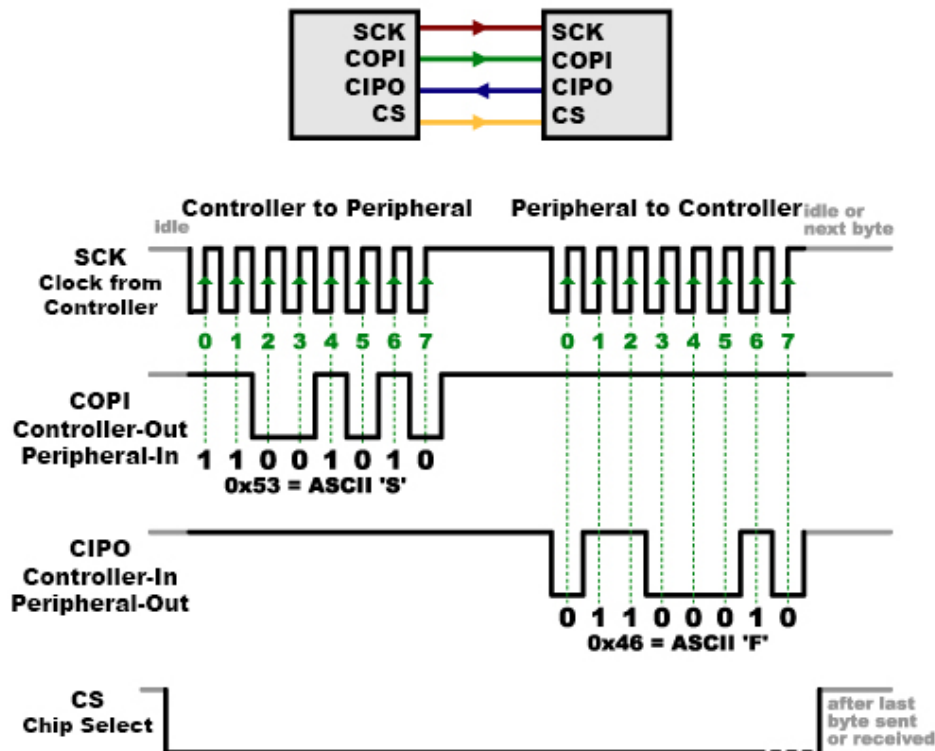

Fig. 19: Full SPI system working with 1:1 controller and peripheral using the falling edge on the clock signal

3.4.4 UART

UART stands for Universal Asynchronous Receiver/Transmitter. It essentially acts as an intermediary between parallel and serial interfaces. When it comes to practicality we used to see UART used on a multitude of devices including printers, mice, and modems. But with newer and more modern technology we have replaced the UART with USB. But even then UART still has applications today especially when working on DIY projects to connect different modules to a microcontroller like what we are planning to do for our project. A stark difference between UART and the likes of SPI and I²C is that UART is not a serial communication protocol, but is a physical circuit with the purpose of transmitting and receiving serial data. This makes it much simpler in concept than that of the other serial communication protocols we discuss in section 3.

UARTs exist as integrated circuits but are more likely to be included inside a microcontroller. This is useful because UART is used to program many devices such as the microcontroller in the Arduino UNO rev 3 which is the ATmega328p-pu which is what we will be using in our custom PCB microcontroller.

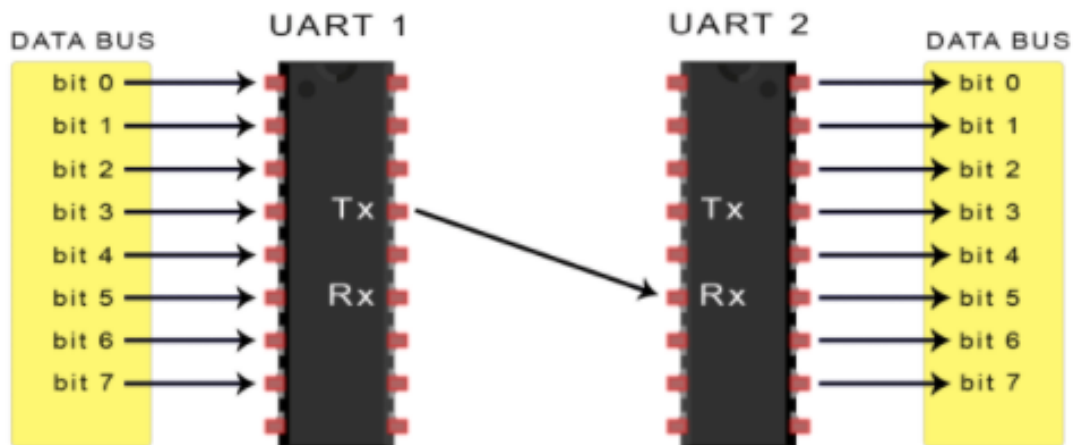

Fig. 20: UART system of two UARTs sending transmitting and receiving serial data

In UART communication we see two UARTs communicating with one another. The transmitting UART converts parallel data from a controlling device like a microcontroller into serial form, then sends the data to the receiving UART which then converts the serial data back into parallel data. UARTs transmit data through a Tx pin and receive data through a Rx pin.

UARTs are asynchronous and therefore do not have a clock signal to synchronize the output bits and the sampling bits. Instead of a clock the UART uses stop and start bits in a data packet when transmitting data. When a UART receives a start bit it will read transmitted bits at a specific rate called the baud rate. Baud rate is the measurement of the speed of data that is being transferred often expressed in bits per second. For the transmitting and receiving of data to work between two UARTs they must operate at the same baud rate. If the baud rates do differ they can only have a small difference otherwise the timing will be off for the transmission and receiving of data. If the timing isn't correct then the bits read will be potentially incorrect. Both UARTs also must be configured in the same way in terms of transmitting and receiving data packet structure. Below is an example of a packet structure.

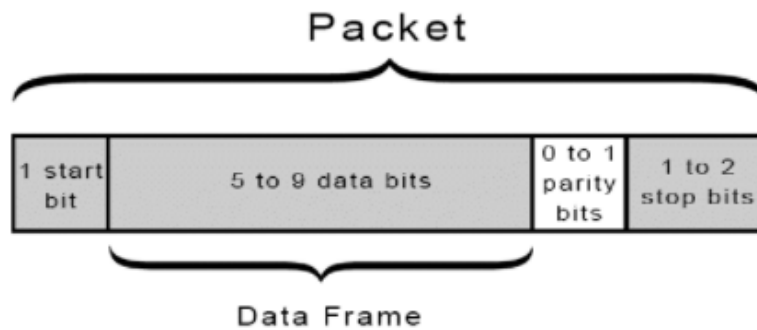

Fig. 21: Example of a packet structure for a UART

In our example packet structure we can see the main components of a packet including the start bit, the data frame, the parity bit, and the stop bits. The UART Tx line is held at high voltage when not transmitting data, but goes to low voltage for one cycle to start the transfer of data. When the Rx line of the receiving UART detects a high to low voltage change it begins to read the rest of the data packet starting with the data frame. The data frame is what holds the data that you are transferring to the second UART. It can be between 5 and 9 bits long.

When the data is sent from UART to UART is sent with the least significant bit first. The parity bit exists as a way to tell if any data has been affected in the transmission of data between UARTs. Anomalies such as differing baud rates and electromagnetic radiation can cause errors in the data. When the UART reads the data frame it counts the number of bits with binary value of 1 and checks if the total is an even or odd number. If the parity bit is 0 then the total bits with binary value 1 should total to an even number, if the parity bit is odd then they should total to an odd number. If the parity bit matches the data then the UART knows that the data is free of errors after transmission. If the parity bit is off from what it should be after counting the total then we know that the data has been affected by an anomaly. The stop bits tells the UART that it is at the end of the transmission of the data packet. The transmitting UART sets the transmission line from low to high for two cycles to signal the end of the data packet.

Lastly the advantages of using UART includes: you only need two wires between UARTs, no clock signal needed, has error checking, data packet structure can be adjusted, and is a mature technology with lots of documentation. The disadvantages include: the size of the data that can be transferred is limited to 9 bits at the max. UARTs only work one to one unlike SPI, and the baud rates of UARTs must be within 10% of one another.

3.4.5 I²C

I²C stands for Inter-Integrated Circuit. I²C has the best of both worlds when it comes to serial communication protocols. You can connect multiple peripherals like with SPI, while also having multiple controllers that control multiple or single peripherals, I²C does not have many limitations when it comes to communication between devices. This is all very useful if your application requires multiple microcontrollers sending information and controlling a peripheral device such as a memory card or a LCD display. I²C also only requires two lines similar to the UART serial communication protocol. This serial communication protocol is important to our project seeing as two of our devices will utilize it.

The lines that I²C uses are as follows:

- SDA(Serial Data): The line for the controller and the peripheral to transmit and receive data from one to the another
- SCL(Serial Clock): This line contains the clock signal

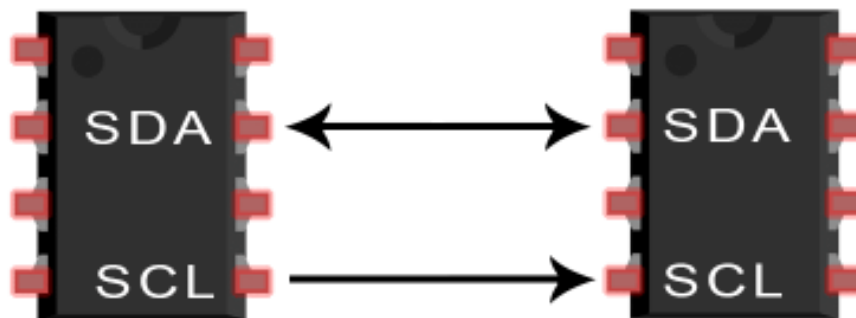

Fig. 22: The controller and peripheral in an I²C system

I²C is also synchronous in that it utilizes a clock much like the SPI serial communication protocol. This means that the output obits and the sampled bits are synchronized by the clock signal that is sent between the controllers and the peripherals. The clock signal for an I²C system is always controlled by the controller.

I²C data is sent through messages similar to the packets in the UART serial communication protocol, but with multiple frames and many bits. Every message had an address frame and one or more data frames. The address frame includes the binary address of a controller. The message also includes start and stop conditions similar to UART's start and stop bits. While also including read/write bits and ACK/NACK bits between every data frame. Below is an example of a message that could be utilized in an I²C system,

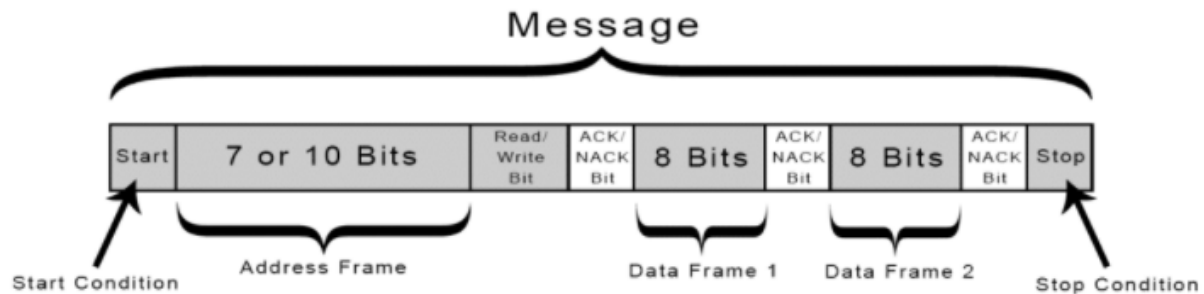

Fig. 23: A message that can be sent between a controller and a peripheral in an I²C system

To be more specific a message in an I²C system contains the following:

- Start Condition: SDA line switches from high to low voltage before the SCL line switches from high to low
- Stop Condition: SDA line switches from low to high voltage after the SCL line switches from low to high
- Address Frame: The address frame contains a 7 or a 10 bit sequence that is unique to each peripheral that the controller wants to send or receive data to. This is how the controller picks which peripheral to send or receive data from.
- Read/Write Bit: This bit determines whether the controller is sending data to the peripheral or the peripheral is sending data to the controller. Low voltage means that data is being sent to the peripheral and high voltage means that the controller is requesting data from the peripheral.
- ACK/NACK Bit: Every frame in a message is separated by a ACK or a NACK bit which stand for acknowledge and no-acknowledge respectively. When an address frame or a data frame is received successfully the receiving device whether it be peripheral or controller sends back an ACK bit to the sender, otherwise the device will send an NACK bit

I²C uses addressing instead of having peripheral select lines like the SPI communication protocol. If the address sent is correct then the peripheral will send back an ACK bit. When the ACK bit is received the data frame is then ready to be transmitted. Data frames are transmitted with the most significant bit first and with 8 bits. With each frame followed by an ACK or a NACK bit in which an ACK bit is required for more data to be sent. Once all data is submitted the message will be closed out with a stop condition.

Lastly the advantages of using the I²C communication protocol include:

- Only requires two lines
- Has the ability to utilizes multiple controllers and peripherals

- Has a success check in the form of the ACK/NACK bit so data is sent or received successfully
- Hardware is relatively simple when compared to other serial communication protocols
- It is a well known and very popular serial communication protocol

The disadvantages for I²C include:

- Slower data transfer rate than some of the other serial communication protocols such as SPI
- Data frames are limited to 8 bits a frame
- Hardware is simple but not as simple as SPI

3.4.6 Comparison of Serial Communication Protocols

In this section we will go over and compare the different serial communication protocols and choose one that best suits the design requirements for our project. Below is a table comparing the different serial communication protocols.

Features	SPI	UART	I ² C
Lines Required	4 Lines	2 Lines	2 Lines
Max Data Transmission Speed	Up to 10 Mbps	Up to 115200 baud Usually see 9600 baud	Up to 5 Mbps
Synchronous or Asynchronous	Synchronous	Asynchronous	Synchronous
Max Number of Controllers	1 Controller	1 Controller	No Limit
Max Numbers of Peripherals	No Limit (Depends on controller limit)	1 Peripheral	1008
Compatible with Bluetooth and LCD Devices	No	No	Yes
Protocol Selected	Not Selected	Selected	Selected

Table 1: Comparing prospective serial communication protocols that we may use to communicate between our devices

Using the above table we are able to determine which serial communication protocol we want to use to communicate between our devices. The protocol that best suits our projects needs would be the I²C protocol and the UART protocol. I²C lets us send and receive data between multiple devices easily with little code. Also finding compatible devices that use the SPI serial communication protocol that are relevant to our project is rather difficult while there are plenty of I²C and UART serial communication protocol compatible devices to choose from. UART is used for a lot of programming purposes with microcontrollers, but we will be using it for bluetooth communication. Later on we will compare these I²C and UART compatible devices and pick the ones that best suits our project.

4 Design Constraints and Standard (10-15 page)

4.1 Related Standards

Various standards are important when creating any project, as a standard helps ensure the customer what they are purchasing. Conforming to these standards is essential if the product is to be marketed. Later, in section 4.2, the impact of each specific standard is discussed and how it applies to this project specifically. Standards can be found in multiple different locations, however the most popular are as follows: The Institute of Electrical and Electronics Engineers Standards Association (IEEE SA), IPC (formerly the Institute of Printed Circuits), and A National Resource for Global Standards (ANSI, formerly known as the National Standards Systems Network). Generally, IEEE SA will have standards that are more specific to the field of electrical and electronics engineering, IPC deals with standards related to printed circuit board design, while ANSI is much more broad and covers most subjects, even those that may be engineering.

The main purpose of having standards is to keep the entire globe “on the same page” by creating a set of requirements and specifications that everyone, across the planet, can follow in order to make sure products are consistent between companies. Furthermore, someone in any country will be sure that the products are safe and dependable. Many standards are used in every engineering project, even if they are not directly involved in the design. All pre-built components need to be standardized, such as a power cord, computer language, or how a test process is properly completed, among many others. A discussion of technical standardization can not be had without mentioning both the International Organization for Standardization (ISO) and International Electrotechnical Commission (IEC) which, together, make up the ISO/IEC Information Centre. Standards apply at multiple different levels of the design process, including (but not limited to): international standards, national standards, and company level standards. The large variety of standards organizations establish guidelines across many different and unique applications.

When purchasing an electrical component, it is important to understand that all there are multiple safety agencies worldwide that define safety requirements for equipment, and there are strict guidelines. Electrical equipment that is poorly made may malfunction and cause multiple safety issues, though the most notable are electrocution or fire. When purchasing equipment, such as a wall outlet AC to DC converter, the circuitry must be withheld to high standards set by one of various different international Certification Bodies (CB). Fig. 24 shows many of the different

bodies that exist to ensure the product one purchases off the shelf is held to the highest safety standards. Purchasing a product that has not complied with these standards is not just a danger to yourself, but to everyone else. In America, the logo to look for Underwriters Laboratories, or UL. This is the top left logo on the image below. The global bodies ensure that anyone within their region can buy a product withheld to the same standards. For example, the Conformité Européenne (CE) logo for a German product carries the same weight as the CE logo on an American product, and the same can be said for many of the others listed below.



Fig. 24: Symbols of various Certification Bodies worldwide

4.2 Relevant Standards

<https://www.ansi.org/education/standards-education-training>

IEC document 602825-1 is the most notable and primary standard for laser usage, classifying each laser into “classes” that describe precautions that should be considered when working with this type of laser. Below is a list of all different classes and their descriptions as seen in table 2:

Lasers come in many shapes and sizes, but certain wavelengths and types of materials can classify them for easy use across many applications. There are four main types of lasers: CO₂ (Carbon Dioxide) , Nd: YAG (Neodymium: Yttrium Aluminum Garnet), Nd: YVO₄ (Neodymium: Yttrium Vanadium Oxide or Yttrium Vanadate), and fiber lasers. While there are others, these are by far the most popular. CO₂ is common for lasers made using gases, and has a wavelength of 10.6 μm. These are used for marking labels, processing, and cutting. YAG and YVO₄ are both commonly made with solid

Class Name	Description
Class 1	<p>Very low risk, “safe under reasonable foreseeable use”, very few precautions need to be taken. Low output power at or below 40 μW, considered “very low power lasers / encapsulated lasers”.</p> <p>Class 1M lasers exist between 302.5 nm and 4000 nm, and are safe except when used with optical aids.</p>
Class 2	<p>Emits visible light between 400 nm and 700 nm. Considered safe for normal operation, but precautions still need to be taken. A laser pointer is generally classified here. Output power is below 1 mW, considered “visible very low power lasers”.</p> <p>Class 2M lasers exist between 400 nm and 700 nm, emitting visible light. Potential for hazard when viewed with optical instruments.</p>
Class 3	<p>Generally safe, but more precautions need to be taken. Power output varies between the different class 3 lasers. While danger exists, these only affect eyes under direct exposure, where reflections are considered safe.</p> <p>Class 3R lasers are “low power lasers”, with a power output of around 5 mW. Safe if handled properly.</p> <p>Class 3B lasers are “medium power lasers”, with a power output approaching 500 mW. These are very hazardous if direct eye contact is made.</p>
Class 4	<p>Extremely unsafe, and multiple precautions need to be taken to ensure safety. Considered “high power lasers”, and can harm eyes, skin and are potentially even a fire hazard. Diffuse reflections are hazardous as well. There is no power limit, since this is the highest possible laser classification.</p>

Table 2: IEC laser classifications

materials, usually with a fundamental wavelength of 1064 nm. These laser types are created with marking & microprocessing and situations where stable and powerful lasers are necessary, respectively. Solid-state lasers are generally considered the most common, with Yb (Ytterbium) and LD (laser diode) lasers being useful and prevalent as well. All of these laser types are amplified through a cavity, where light is reflected over

a mirror numerous times to create a powerful beam that exits the cavity and is seen as laser light. The final type of notable laser is a fiber laser. These instead amplify light through a long fiber, which will be discussed in more detail in section 4.2.

Another important specification of lasers to be wary of when choosing a laser are the different standards of laser wavelengths. Below, the most common wavelengths will be discussed from longest to shortest, with a brief summary of the reasoning behind using each one. The lowest frequency (or highest wavelength) laser standard is 10600 nm, which has the fantastic ability of penetrating through multiple objects, since it is not easily absorbed through common materials such as water or metal. Commonly, this is used for surgical procedures, as it can easily travel through skin and blood to target abnormal growths below the skin surface. This is not useful to our project, but is still an important standard to have regardless, as a medical professional would be able to easily select a laser with 10600 nm for their purposes, knowing that it will be excellent for their applications, regardless of their prior knowledge of optics and photonics. The next longest wavelength is 1064 nm, and is likely the most versatile and widely used of all laser wavelength standards. This is within the infrared spectrum (just above the visible light spectrum in wavelength), and while invisible to the human eye is also able to pass through transparent objects, such as glass. It also has a certain amount (thought less than 10600 nm) of penetrating power, making it useful for medical professionals performing an operation just below the skin-level. However, its most notable use is in processing materials, making it the ideal wavelength for this project. Having a laser standard for this wavelength ensures that we acquire a laser that is suitable for our needs. The next standard is 532 nm (half of 1064 nm) which is a green color. This wavelength is applicable in situations where an object would normally reflect the 1064 nm infrared laser, such as in transparent objects or high absorption rate metals. The last standard wavelength is 355 nm (ultraviolet) and finds its niche in scenarios where objects are immensely high absorption rates are required where the 1064 nm and 532 nm would just pass through the object. Usually, these are used in a manner similar to this project, but for specific objects that would not be tested in this experiment. The main takeaway from viewing the four main laser wavelengths is that a standard is created in order to make selecting a laser much simpler, and experiments or applications easy to replicate when used at any location worldwide.

Since the project's software will be created using C, a standard needs to be addressed for understanding proper usage of this language. Specifically, this is called *ISO/IEC 9899:TC2* which "specifies the form and establishes the interpretation of programs written in the C programming language." [12] Mainly, this is a method of using C code through its representation of C programs, syntax and constraints, semantic rules, representation of input and output data, and restrictions. These standards are co-developed by the ISO and IEC, who have a mutual interest in collaboration to create this international standard for the C language. The C language is an old programming

language, and many changes have been made throughout its history. Some notable and more modern changes are as follows: more floating point characteristics, variable length arrays, complex number support, and the long long int type, among many others. The fact that this standard is regularly updated means that it is relevant to our project and will be useful for software development of our algorithms. The most recent update is from May 6, 2005. This document comes in handy wherever a question arises about programming in the C language, whether that be conceptual, syntax, or creating an algorithm.

The standard *IEEE 802.15.1-2002* is the IEEE standard addressing wireless communications within a personal area network (PAN). The *IEEE 802.15* is a group within IEEE that has expertise in these wireless personal area networks (WPAN) standards. Specifically, *IEEE 802.15.1* specifies Bluetooth. The 2002 in the standard name above shows the year these standards were published. Since this project utilizes a Bluetooth module to remotely access the data output from the computer, this standard is essential to properly implement the bluetooth module for a user to understand. The name "Bluetooth" can not be arbitrarily assigned to any wireless device, as it is held to strict standards and must comply with all of them. More specifically, Bluetooth "is an industry specification for short-range radio frequency (RF)-based connectivity for portable personal devices." The specific requirements for the physical layer (PHY), medium access control (MAC), service access points (SAP), and the logical link control (LLC). Lastly, there are software standards involved with bluetooth. This document provides the Protocol Implementation Conformance Statement (PICS) with the necessary specification and description layer (SDL) model within the bluetooth sublayer. Essentially, this document provides all the necessary information on creating a product using Bluetooth with as little complexity as possible along with low power consumption. Despite not being the newest version, it is the most relevant today.

ANSI-1064A & IEC-6LR61 describes the battery standards for our project. More specifically, a 9 V battery. There are exact specifications for the standard in order for a battery to be sold as a '9 V battery'. Some of the specifications that need to be recorded are the cell chemistry (ex. Zinc-Manganese Dioxide), nominal voltage (which will always be 9 V), the operating temperature (ex. -18°C to 55°C), the weight (usually around 45.5 grams or 1.6 oz.), the volume and dimensions (9 V batteries are rectangular prisms, with around 20 cm³ of volume, and the terminal type (ex. snap), the jacket type (ex. steel), and the shelf life. The *ANSI-1064A & IEC-6LR61* specifically give a designation for a battery, making it easy to find any battery from any brand that follows these specifications and using them interchangeably.

ENERGIZER 522



Industry Standard Dimensions

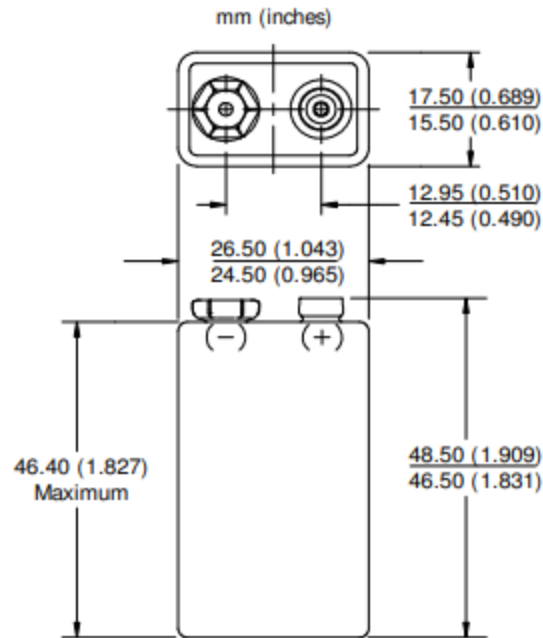

Fig. 25: Example of the dimensional standards of an Energizer 522 Alkaline battery (source: <https://www.datasheetarchive.com/pdf/download.php?id=16aa6282917a060bb238bcd33ebbd82c1e5c1f&type=P&term=ANSI-1604A>)

4.3 Design Impact of Relevant Standards

All of the above standards described in section 4.1 are important to understand and their relevance to our project will be specifically addressed within this section. Some of these will change how testing is conducted, others will affect our design procedure, and others describe the selection of various components.

IEC document 602825-1 on laser class safety describes the various different laser types, explaining the distinct power outputs, safety precautions, and hazards associated with each one. Since our project utilizes a Class 4 laser, it is essential to understand how this affects the project's completion. A high powered laser such as

this one should not be treated with indifference, as there is a serious possibility of getting hurt or causing damage to the surrounding environment, such as a fire. Since these lasers also reflect hazardous amounts of power, it is also important to understand how to contain this power. Goggles need to be worn when working with these lasers, so that hazardous wavelengths are filtered out. Furthermore, UCF requires that students undergo laser safety training before entering the laboratory space, and review the lab safety guidelines before entering the lab space. Lastly, beam stops are in place to prevent lasers from reflecting off unintended objects. Though the laser will generally be operated at much lower power levels (around 80 mW), it has the potential to be exceptionally dangerous. More information about specific components is included below in section 6.2.

As stated above, there are various standards for types of lasers to select from, but our project specifically utilizes fiber lasers. While other lasers use a cavity to reflect light and amplify its strength before it is output, a fiber laser instead amplifies photon energy through a very large fiber; this has the same effect but with different pros and cons. This is selected mostly due to its portability. More specifically, the fiber and laser medium can be combined into a single optical system. “Using a fiber as a laser medium gives a long interaction length, which works well for diode-pumping. This geometry results in high photon conversion efficiency, as well as a rugged and compact design. When fiber components are spliced together, there are no discrete optics to adjust or to get out of alignment.” [13] Since our project intends to be able to create a laser that can be moved around to detect objects and have use for real-world scenarios, where exact precision may not be possible, the fiber laser allows high efficiency, end-user ease of use, and a more compact design. Engineering projects always need to take into account CSWaP, and the fiber laser realizes a decrease in both cost (C) and size (S).

ISO/IEC 9899:TC2 describes the proper usage of the C programming language, which is what has been selected for this specific project. It will be used on our embedded systems to create our LCD and bluetooth, with I2C communication. A deep understanding of the language is necessary to complete the project, and this documentation provides every standard on using it that has been accepted internationally. Most notably, there are “shall” and “shall not” statements made throughout the document that describe standards that need to be met (or standards that should not be completed, as they are improper). To ensure that the program complies with the ISO/IEC standards outlined in this document, checking through these statements to ensure compliance with all will confirm proper C programming usage without a reasonable doubt. This is important if someone else were to refer to the code. Because of how standards are created, this means that a person in a location around the globe could use our code without any issues, assuming they also refer to the same ISO/IEC standards.

IEEE 802.15.1-2002 which describes the standards of Bluetooth is extremely useful for our purposes, since we have a Bluetooth module. When the Bluetooth standards are realized, the user will have the ability to connect the device to any pre-existing device that also utilizes Bluetooth standards, such as a phone, desktop computer, or laptop. Essentially, our devices would not provide anywhere near the useful it currently does without the standardization of Bluetooth. On top of that, it also provides simplicity, as implementing this wireless connection becomes extremely simple. The Bluetooth module provided pre-implements almost all of the standards required for the wireless communication to take place, however, it is important to understand the specifics should an issue arise and need to be troubleshooted and so that the product can be understood by others. It is notable that the standards have not changed since 2002, proving that the standards are set in stone and should not be altered. If the project were to at all modify from the standards, there is a very high likelihood that the project will not work at all. Should all standards be followed precisely as described within the IEEE document, the project will work flawlessly with all other devices using the Bluetooth standard, which is the desired outcome. This signifies the importance of these standards and why they need to be followed closely and precisely.

ANSI-1064A & IEC-6LR61 standards for 9 V batteries are some of the most important standards to pay attention to when creating a wireless device that utilizes this battery type. The most important factor of the 9 V battery standards is the size of the battery and the nominal output. Obviously, the nominal output will be 9 V, hence the name '9 V battery'; however, the dimensions need to also be exact in order to fit into a battery holder. In order to make the project batteries interchangeable with any other 9 V battery, they need to follow strict guidelines of *ANSI-1064A & IEC-6LR61*, otherwise it will not fit properly, hence making it useless. Overall, these standards ensure the product can be used universally and easily by using batteries that can be acquired from nearly any store for a low price.

4.4 Realistic Design Constraints

It would be great if things that can be done theoretically could be done in real life. However, most of the time, this is not the case. This occurs because of the many variables actually involved in the implementation of a device, going from paper to application. On paper, we usually make approximations, decide to ignore factors that we consider to be negligible, and to simplify analyses as much as possible to focus more on the topic at hand. In this case, the topic at hand is SRS and the fact that we want to use it for collecting spectral reflectivity measurements with an electronic device that we will build.

Beginning with our original idea, we wanted to use a hollow-core PBG. This type of optical fiber would have enabled us to fill the core and cladding with hydrogen gas. Since hydrogen gas has a neatly defined Raman emission, we wanted to take advantage of that. Also, the Raman gain for hydrogen is 2.64cm/GW, which would enable us to use a short fiber and get good results. Not to mention that hollow-core fibers enable the use of higher laser powers because most of the light travels in the hollow-core and not glass. We had an extra worry, however, which was being able to tightly pack the gas inside of the fiber by carefully placing it inside of gas cells. These gas cells were a bit risky since gas could leak out from them and be a potential health hazard. Also, just having to build the cells, put the fiber in, and struggle to align it with a laser would have been too tedious to do in a short amount of time.

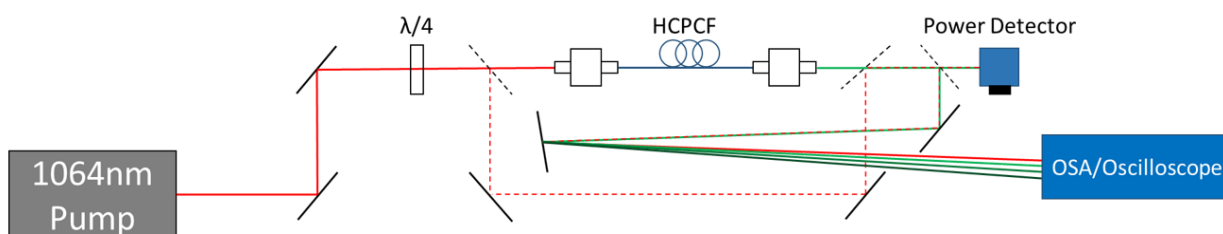

Fig. 26: Original optical setup with fiber placed in a gas cell. Note that this setup only accounts for the characterization of the Raman signal.

This all sounded good on paper, and promising when considering, but constraints started happening. First of all, we learned that hydrogen gas is very risky to work with and there are no labs at CREOL, The College of Optics and Photonics, where we could have built this setup. Not to mention that to have gas, we would have had to use the big metal cylinders, which themselves are a safety risk and training would have to be done to appropriately handle them. Another constraint to this idea, like mentioned before were the gas cells. Hydrogen gas tends to leak out of small gaps, and we would have had to design or build from a design, the gas cells ourselves. There would have been risk of gas leakage, so we didn't want to have to deal with filling the gas cells up every so often.

In addition to the difficulties that gas brings, it would have been more expensive overall to have this idea go through. It's also important to mention that despite this, we were going to go through with gas, but what made us reconsider was the safety concern. This made us reconsider our project, but thanks to our sponsor, using silica glass as a Raman gain medium became a possibility. Therefore, using a silica fiber became our first design constraint because of safety, cost, and ease of building.

There are some limitations when it comes to using silica fibers, however. The first being the amount of light that can be launched into the fiber. Since silica gets damaged with very strong laser pulses, we limit the amount of power that we launch into the fiber to a

maximum of $3GW/cm^2$. With this amount of power, SRS is still possible to be obtained in a silica fiber. Another consequence of using silica is the Raman gain. The Raman gain of silica is $0.92 \cdot 10^{-11} cm/W$. This is a significantly smaller Raman gain than Hydrogen.

Having to use a lower laser peak power with a lower Raman gain, a longer fiber is needed. We have found in literature (from Cohen et. al) that SRS has been achieved in silica before (as mentioned in previous sections) with a 176m long fiber. The difference between this fiber and ours, however, is that in literature a regular step-index single-mode fiber was used. This introduced some polarization scrambling. In our case, we are going to have negligible polarization scrambling due to the PM-SM fiber that we will be using. With a new factor of 2 in our calculation of the threshold length of the fiber, we conclude that about $\sim 100m$ of fiber will be optimal to get a really good Raman signal by using a peak power of $1GW/cm^2$.

This design constraint brings about another issue in the Raman signal. The first sets of Stokes frequencies are narrow and almost neatly defined. However, for 3rd, 4th, and 5th order Stokes frequencies, their spectrum begins to broaden. This broadening of the spectrum is something that we are interested in seeing on the oscilloscope, as it will give us an idea on how to properly filter out undesired frequencies with an iris, but with the caveat of registering a lower power. Like mentioned before, another thing that we can do is just put enough power through the fiber to be able to generate the first two Stokes orders and use those for spectral reflectivity content.

In summary, these were our two optically-challenging design constraints. On one end, using gas is very promising and the results that we would get are good, but using gas is expensive and requires more training, gas cells to keep the gas in the fiber, and a specialized room to build the setup since hydrogen gas is rksy. We then took the constraint of not being able to use gas, to then try using a silica fiber. This fiber has a lower Raman gain and we will not be able to pump it as much as a hollow-core fiber, but with a longer length, it will yield good and interesting results that we are going to have to be able to work with and adapt to later.

On the electrical side of things we wanted to design a PCB that would be able to take values from the oscilloscope in the form of a TXT, CSV, or even an excel file to run signal processing algorithms in similar forms that you would on a computer. Our first thought when thinking about designing and building a PCB was to design something similar to that of an Arduino UNO because Arduino's have open source hardware and software. There are also an extensive amount of projects done on the arduino platform so we would have many references to look at if we get stuck. But after further research of the arduino platform we realized it does not have the capabilities that we require which are parsing and editing a TXT, CSV, or Excel file. Even if we were able to get the

arduino like device to start analysing one of the file types it would be incredibly slow. So we were back to the drawing board.

We began research of designing our very own microprocessor similar to that of a Raspberry Pi that could run a program such as Matlab or Python so that we could process the information from the oscilloscope files. We learned that designing and building something like a Raspberry Pi is very complicated and requires a four or more layer board which we decided is beyond our capabilities in PCB design. But we were able to find a compromise between having enough processing power and a low complexity printed circuit board. This compromise is using a computer to do the signal processing and to send the information via bluetooth over open space to our custom PCB using a bluetooth module. This allows our board to display any important information we need on a display while also being mobile and low complexity.

Another limitation we thought about was the limitations of bluetooth. Bluetooth can be power consuming and can also be short ranged which would not be ideal if we want our device to be able to be used while being more than a short distance from the computer. A solution to this would be to choose a bluetooth module that has a long range and low power which we will go over later in our document. The display is also a limitation for our project because our MCU will only be compatible with certain low resolution displays. These displays compatibility are determined by the communication protocol that they use. MCU's only have so many serial communication protocols that they can use.

4.5 Economic and Time Constraints

For our project, the most expensive parts were the ones involving the optics. Due to how precise everything has to be and the materials used for the optical parts, even a simple beam stop was about \$400. Fortunately, our sponsors including AFRL and UCF faculty helped with this. Most of the optical parts were bought and loaned to us by AFRL while other parts were loaned to us by UCF faculty.

The most expensive device that we will be using is the high bandwidth oscilloscope. Because of this device's bandwidth, it is estimated that the cost of this alone is \$100,000 or more. Being generous with our budget estimates, we set that amount as the cost. However, due to its bandwidth, the price may actually be around \$200,000. The second most expensive device, which AFRL already had, was the 1064nm pump fiber laser. We estimate that the price of this laser is around \$30,000. These two devices alone are the two greatest economic constraints. If our UCF faculty sponsor and AFRL did not have these devices, we would have been unable to carry out the project.

All other optics-related parts are being purchased by AFRL. So far, no budget limit has been specified on their end, but we are trying our best to keep the costs and the complexity of the system as low as possible. On the other hand, all electrical components are more manageable for us and we are planning on buying them with our own funds. More details on the actual budget and specific prices can be found in the budget and finance section.

Time constraints are another vital factor in project design and creation, and time is a valuable resource that should not be taken for granted; because just like money, time is limited. This project has two main deadlines, as the course is divided into two semesters. The first deadline coincides with the end of the fall 2020 semester, on December 8, 2020. This point marks the end of Senior Design I, and at this point, our entire document needs to be written. Undertaking the document is not a small feat, and requires hours of careful planning and writing. While writing the documentation, the research necessary to complete the project is also completed. This means exploring the internet for various research papers and reading up on previous and similar projects to understand and learn from. The final part of Senior Design I is the planning, designing, and parts acquisition phase. Essentially all the time constraints put into place for the first semester are needed in order to ensure preparedness for Senior Design II.

Senior Design II begins on January 11, 2021, though the assembly and testing can begin earlier. This marks the beginning of Spring 2021, and the halfway point of the design project. From this point on, the entire focus will be on building, prototyping, and testing the project before it can be finalized. Although there are fewer objectives, time will still be a huge part of completion in an acceptable time frame. While taking classes and / or working, finding opportunities to complete these tasks will be a challenge, and time should not be taken for granted. Completion will occur by April 2021, since graduation is after this point and we will be unable to continue any work. Throughout our entire project, time is likely the single most precious and valuable resource and should not be wasted; instead it should be utilized to its fullest potential without being wasted on trivial tasks.

4.6 Environmental, Social and Political Constraints

To our knowledge, this is the first time that a device like this has been tried, apart from the hollow-core fiber based hydrogen Rama project by Ausley et. al. Thus, there are no social and political constraints so far. Environmentally there are no constraints either, but it's important to mention that the output power required for a device like this to work is not eye-safe. Therefore, it should not be operated outside unless people and

animals in the vicinity have eye protection. Another important consideration is the average power of the pump and the Raman laser. Despite the pump's maximum average power for this project being 80mW, considerable care must be taken to not burn objects and potentially start a fire.

4.7 Ethical, Health, and Safety Constraints

Because of the nature of this project, there are no ethical constraints for us to worry about when working on it. There are, however, health and safety constraints. Starting with safety constraints, the project involves the use of a class 4 pump laser. This is the maximum rating that a laser can have. Class 4 (as described in section 4.1) means that at high powers, the laser can cause harm to the eyes, not only by looking directly at the beam, but at the reflection from objects. Also, depending on the output power used, skin burn can occur despite 1064nm being in the near-IR.

As a group, we have discussed these issues and have taken the necessary precautions to work on this project. We wrote and signed a safety operating procedure (SOP) to be able to safely and effectively work in the lab with a high power laser. While doing this SOP, we identified the hazard, which was the infrared fiber laser with a center wavelength of 1064nm. Like mentioned previously, severe eye damage (including blindness) and skin damage can result from direct beam and specular reflections. We then discussed the following work practice controls:

1. Only authorized personnel will operate lasers.
2. The laboratory doors will be closed when the laser is operating.
3. A safety screen will be placed in front of doors to prevent any laser radiation from escaping the lab if the door is accidentally opened.
4. Any time the laser is on, the laboratory doors will be closed and the "Laser is ON" sign will be turned on. Additionally a warning sign will be placed over the exterior door handle so that personnel cannot enter the lab without being aware of the laser operation.
5. No other work will be performed in the lab when the laser is in use. Laser operators must schedule the lab at least 24 hours prior to use.
6. Unauthorized personnel will be only allowed entry to the laboratory during laser operation with the supervision of an authorized user under the terms specified by the PI.
7. Laser protective eyewear for sufficient protection against the 1064nm wavelength is available in the storage cabinet. Laser protective eyewear must be worn at all times.

8. Specular and diffuse reflections will be controlled during normal operations using apertures, beam blocks, enclosures, etc. consistent with good laser safety practice.
9. Each time the laser is turned on after an unattended period of time, the laser operator will first conduct a survey for unwanted stray beams or diffuse reflections.

In addition to this, since safety is one of our top priorities, we also made a list of procedures that we must follow:

- A. Reserve use of the lab.
- B. Clear the room of unrelated personnel, turn on the “Laser On” indicator light on the outside of the lab and install the warning sign over the exterior door handles.
- C. Remove watches, bracelets, rings, loose necklaces or any other metal objects that might accidentally enter the beam path and generate a hazardous reflection.
- D. Put on PPE.
- E. Turn on the laser.
- F. Conduct a survey of the beam path and correct any stray beams or diffuse reflections.
- G. Use the laser while being cognizant of the beam path and potential reflections. Always keep your eyes well-above the working plane of the table.
- H. Turn off the laser.
- I. Remove PPE.
- J. Turn off the “Laser On” indicator, remove the handle-covering sign and allow other personnel to enter the lab.

Note that we are planning on getting laser safety goggles and a safety screen for the lab door. The goggles might be from UCF or we might have to order them with AFRL.

Health-wise, we had no constraints either. However, covid is a major obstacle when it comes to working on building the laser in the lab. Because of this, only one person is allowed in the lab at a time during the fall 2020 semester. This made it very hard to work on the device because there was only one person in charge of the laser and making sure that all of the optics were in place. In the spring semester, however, it is expected that more people might be able to be in the lab at the same time. This is crucial because the people in charge of doing the signal analysis portion of the project must be present to relay information from the oscilloscope to the Raspberry Pi for post-processing. Even though this might seem like a constraint, the project is still doable and able to be completed by the end of the spring 2021 semester.

4.7 Manufacturability and Sustainability Constraints

The laser system that we are developing is novel and hasn't been done commercially yet. Therefore, there are no constraints in terms of being able to put all of the optics and electronics in a box or circuit. However, if we were to consider doing this, the amount of optical components and the lack of a small detector/digitizer device would make this very hard to achieve. Like the oscilloscope for example. An oscilloscope like the one that we are using is over \$100,000, so there is no way for us to even attempt at building a device with the same capabilities. However, connecting everything together, the optics, the digitized analog input, the post-processing and beyond can be done in an optical table.

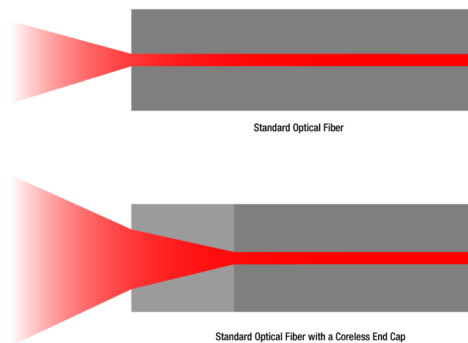

Fig. 27: Fiber without endcap vs. fiber with an endcap. This shows that endcaps help reduce the energy density at the air-glass interface. (Source: Thorlabs.com)

In the optics side of things, we designed the optical setup, considering all posts and post-holders that we were going to need. We considered a great number of lenses, mirrors, polarizers, mounts, and more. However, our biggest manufacturing constraint was placing endcaps on the PM-SM fiber. Optical fiber endcaps are pieces of glass that help protect the front and back surface of the fiber from laser-induced damage. Having these put in our fiber is of great importance due to the powers that we will be working with, specially since we are going to be going beyond the practical and safe limit of $1GW/cm^2$.

These endcaps were manufacturing constraints because they changed the type of lens that we could use to couple light into the fiber. Not only that, but the fiber mounting system had to be adapted to be able to hold the endcaps. Especially since, compared to the 250micron diameter of the fiber, endcaps are 1-5mm in diameter, so special holders have to be used.

Besides this consideration, putting the optical system together is very straightforward. First that pump, which has a wavelength of 1064nm as mentioned before. The laser

that comes from the pump will be aligned by mirrors and polarization optics will be used to orient light correctly into the fiber. This is paramount to obtaining a good Raman gain and, therefore, the waveforms. At the output of the fiber, there will be a target, which will have the laser aimed at it and a detector in front of it (at an angle) to collect the light that reflects from it. This information will then be processed by an ADC (oscilloscope in this case) and then post-processed by the electrical system.

PCB Manufacturing

Modern electronics revolve around the use of printed circuit boards (PCB). It's very hard to find a device that has electronic circuits to not use a PCB as it's vehicle for holding the circuits. A PCB has the ability to connect each component included in the board and is able to support each component connected. To connect each component in a PCB using conductive tracks and pads on one or more layers of copper laminated onto or between sheets of non conductive substrate. Each component is then soldered onto a PCB to connect electrically and to mechanically fasten to the board. Some alternatives to the PCB exist such as the wire wrap and point-to-point construction, but are dated and are rarely implemented.

To design a PCB extra effort is required when determining the layout of the board, but the rest of the manufacturing process can be automated. Electronic computer aided design or Electronic Design Automation (EDA) software exists to aid in the design of the board layout for a PCB. In our case we will be using Autodesk EAGLE to design the board layout and schematic for our custom PCB microcontroller. PCBs are cheap and easily mass produced due to the fact that components are being mounted and wired in one operation. Large amounts of PCBs can be manufactured at the same time. Usually when ordering PCBs it is harder to order less than 10 in one transaction. PCBs can be made manually but this process is much slower and more costly with less benefits and yield. PCBs also have the ability to be very complex or quite simple depending on the layering of the boards. They can be single sided with one copper layer up to multi-layer boards with outer and inner layers of copper alternating with layers of substrate. With more layers PCBs can accommodate more components in a smaller area. Surface mount technology was attributed to the rise in popularity of multi-layer boards. But with more layers a PCB becomes much more difficult to test and repair.

The circuit properties traditionally found in a PCB consists of many traces. Each trace consists of a flat narrow piece of copper foil that remains after the etching of the copper layer of the board. The etching is done by adding an etching resistant surface to the parts of the layer that you don't want to etch away. Each trace's resistance is determined by its width, thickness, and length. Power and ground lines may be required to be wider than signal traces. Typically when designing a PCB, an entire layer copper layer is designated to be ground for shielding and power return.

The traditional design of a PCB includes alternating layers of different materials with the main layers being the substrate and the copper. Each layer is mechanically bonded using heat and adhesive. The layers that are typically found in a manufactured PCB are as follows:

- **Silk Screen:** A layer that is typically added to the top of the PCB to identify the different components, test points, and part numbers that can be seen on the component side of the board. The silk screen can also be used to add warning symbols, company logos, and manufacturing marks. This makes it easier to assemble, test, and to understand the board layout. Silk screen is most commonly white.
- **Solder Mask:** This layer is found on top of the copper foil and is usually what gives the PCB its green color, but PCBs can also be made to have many other colors such as blue, purple, red, black and many more. The solder mask is a polymer applied to the copper traces of the board to protect against oxidation and solder bridges which can happen if there is an unintentional connection made in the soldering process of adding components. When mass producing PCBs, a solder mask is critical when manufacturing boards with the reflow and solder bath techniques. The solder mask includes openings for each component that are to be added to the board.
- **Copper:** The copper layer is made up of thin copper foil. When referring to a board with one or more layers it is typical to refer to the number of copper layers the PCB has. A board can have many layers up to 16 or more depending on the complexity needed for the device. Copper thickness is typically specified by ounces per square foot, where most PCBs have one ounce per square foot of copper thickness, but the thickness can deviate from board to board depending on the power requirements of the board. High power boards can require higher copper thickness. Each ounce of copper per square is about 34 micrometers of thickness.
- **Substrate:** The substrate is the core of the board and gives the PCB its main source of thickness and rigidity. The most common grade of substrate material is designated as FR-4. FR-4 is made up of woven fiberglass cloth injected with an epoxy resin. This material has low water absorption, good insulation, and good arc resistance making it a great candidate for a substrate in a PCB, hence the popularity. FR-4 also has some options when it comes to fabrication. This material also is typically very heat resistant with a common rating of 130 °Celsius.

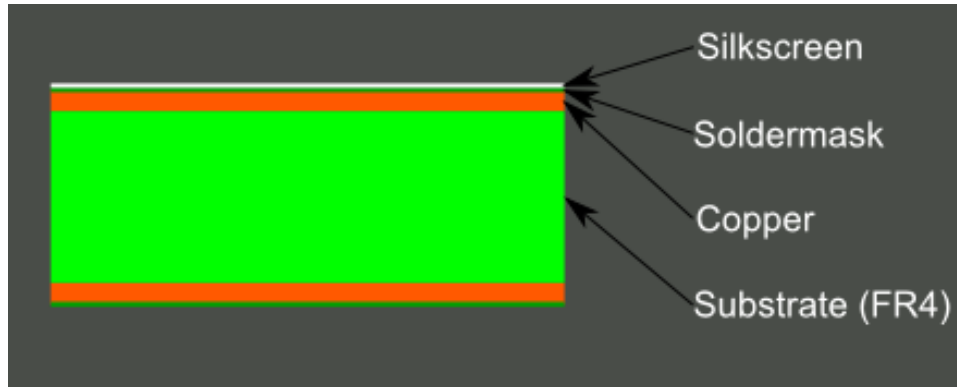

Figure 28: An example of a two PCB

There are many different PCB design softwares out there but we will be using Autodesk EAGLE. Designing a PCB in Autodesk eagle is split into two different editors; the schematic editor which is used for designing circuit diagrams and the printed circuit board layout editor which is where the traces and layers are constructed. EAGLE includes useful features like back annotation and auto routing which automatically connects traces based on the schematic. EAGLE provides an intuitive interface and menu system for editing and creating PCBs. When completing the design of a PCB Autodesk EAGLE also includes CAM software that can export Gerber files which are the universal language for printed circuit board manufacturing. An example of our custom PCB Microcontroller's gerber files that have been processed by a manufacturer are shown below.

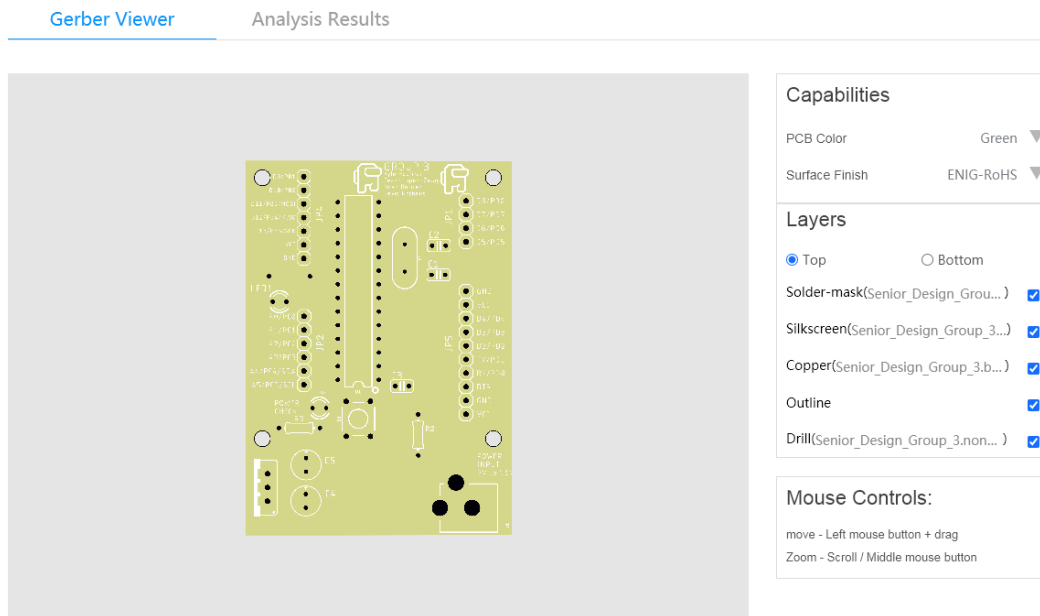

Figure 29: An example of Gerber files being processed by a manufacturer (in this case by JLCPCB)

After the Gerber files are processed by the manufacturing company they give you multiple options in what to include in the board such as material and color. In our case we chose green and lead free. From there you pay and your boards will be on their way, with many manufacturers requiring a minimum of five boards or more ordered at a time.

PCBs when made to be high quality are long lasting and make devices run for many years without fail. But to be high quality there are some factors that need to be counteracted such as leakage resistance, voltage drop, stray capacitance, and dielectric absorption. PCBs also like to absorb water from the atmosphere from humidity.

These factors can be counteracted with partitioning, decoupling, thermal management, good tracing of the PCB, and proper grounding. All these combined leads to a higher quality and more reliable printed circuit board. Partitioning is the process of physically separating digital and analog signals so that there is no unwanted transfer of signals between the two. If there is unwanted transfer of signals there is a way to separate the signals by looking at the edges of the signals. Another important thing to do when designing a PCB is add extra ground pins, because the contact resistance of a pin increases with age, which will affect the printed circuit board's performance. There also should be extra power pins for this reason also.

Unlike large electronic circuits, it is important to keep track of trace resistances in printed circuit boards because trace resistances can decrease performance of the board. These resistances can cause a voltage drop. The method to combat this would be to use voltage sensing feedback which a long trace is used to hold the input of a high resolution ADC with low input impedance. It is also important to track and keep inductance and capacitance in control. The most important and seemingly simple concept is grounding. Issues with grounding can cause major inaccuracies and hurt the performance of the board. The use of ground planes such as using a copper pour can fix these problems.

In a nutshell it is important to follow design standards and recommended techniques when designing a printed circuit board layout. This is because critical failures can occur otherwise which would not be optimal if you are selling to a customer. These techniques and standards are also important if you want your printed circuit board to be easy to use and easy to read. Our design approach to our project was to have the board layout be as simple as possible while achieving all the goals that we need our electrical system to achieve. This is done through following the above constraints and avoiding possible failures while maintaining a high quality board with every component labeled and easy to read.

5 Design (25-30 pages)

5.1 System Overview

CAD is an electro-optical system that takes advantage of nonlinear optical phenomena and temporally-spaced laser pulses of different wavelengths to detect the spectral reflectivity signature of objects and classify them. Then, with an LCD screen, results are shown and the user receives information about the object, reflectivities, and possibly range. This kind of system could be extremely useful if used together with LADAR technologies due to its ability to improve the detection capabilities of the system by taking advantage of multiple wavelengths. As a side note, a major advantage that working at this wavelength range provides is the fact that the reflectivity of soil and plants is much different at this range. Making this ideal for defense, agricultural, and archeological applications.

One of the greatest challenges encountered when doing this is how the different wavelengths are put together on the output side and registered in the input side of the system. Conventionally, LADAR systems that take advantage of multiple wavelengths require bulky optical setups to join everything in a single output and then separate everything spatially in the input side. Our device eliminates these needs by using just one pump wavelength, 1064nm, and producing 2-4 different new wavelengths in a conventional polarization-maintaining silica fiber. Then, this output consisting of multiple wavelengths is directed at an object. Depending on how much an object reflects a certain wavelength and how much the individual wavelengths that come out of the fiber are spaced out in time, our signal analysis algorithm will be able to take this information.

This is contingent on the speed of the ADC that we will use. To be able to correctly observe all of the rise times and wavelengths that might not be spaced out by much time, we plan to use an Agilent infiniiium DSO81204A, 12GHz, 40GSa/s oscilloscope. This will be connected to a Thorlabs high-speed InGaAs detector capable of resolving wavelengths in the NIR or SWIR bands that are incredibly fast-changing.

Upon passing this information through the signal analysis algorithm, a set of information will be generated, which includes the overall waveform envelope, the reflectivities of the object being scanned, and what the object is. This will be sent to an electrical subsystem that will receive the information via bluetooth and then display it in an LCD screen. As it can be seen in the figure below, when putting both the optical and electrical subsystems together, CAD is born.

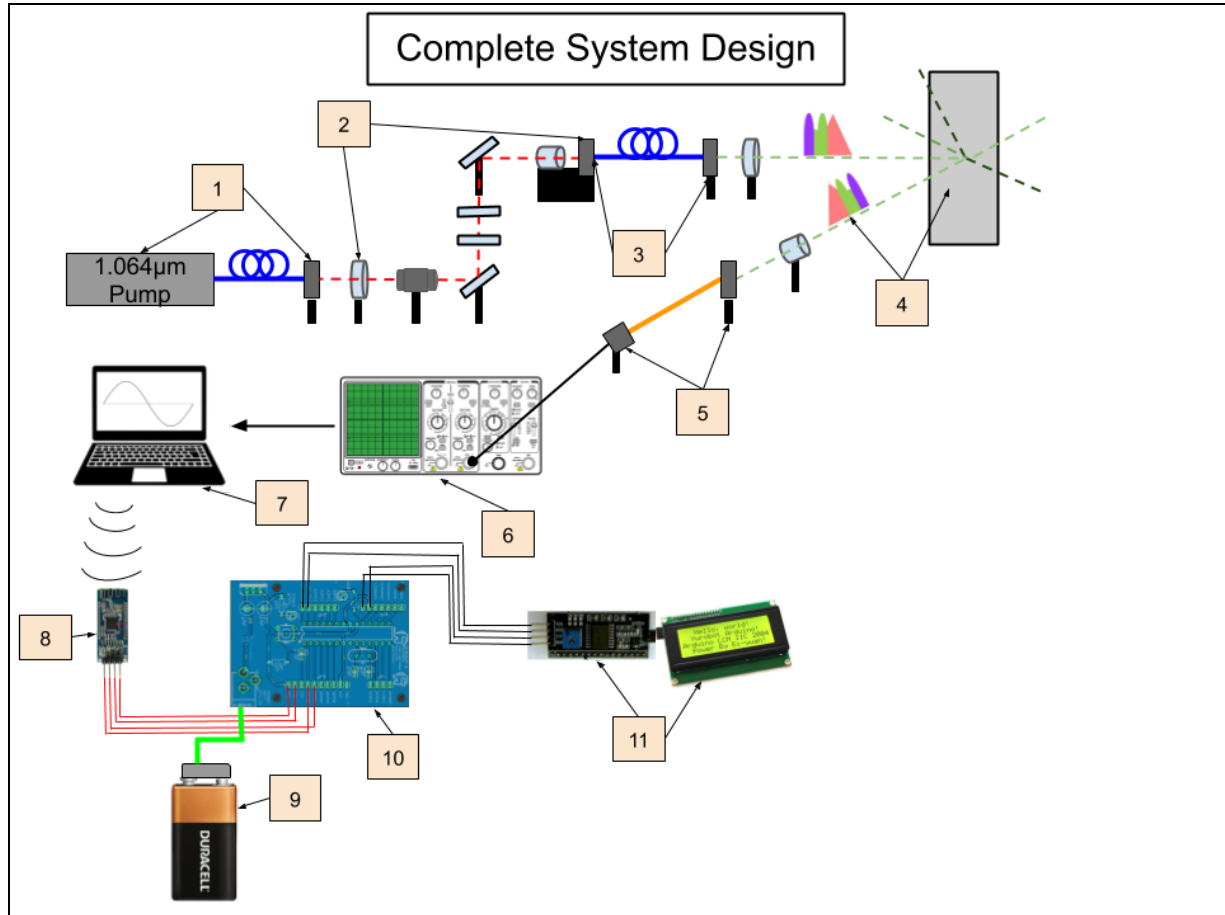

Fig. 30: Schematic of CAD showing how both optical and electrical subsystems will be connected together via components 5, 6, and 7.

System Design Legend

1	Pump laser controller and 1.064 μm wavelength fiber-laser pump	7	Computer/ Post Processor
2	Collimation, polarization, and alignment optics	8	Bluetooth Module
3	PM-SM Fiber	9	9 Volt Battery
4	Object and output waveforms	10	Custom PCB Microcontroller
5	Single Fiber with FC/PC connector and Detector	11	20x4 LCD Display with I ² C
6	Oscilloscope/ADC	12	

In the following sections, the overall system will be broken down into two parts: the optical subsystem and the electrical subsystem. Each part will delve much more in depth about how everything is put together, the exact parts used, parts considered, and more.

5.2 Optical Subsystem Overview

The optical subsystems portion of this project are critical to the operation of the system as it is responsible for creating the raman scattered wavelengths and collecting the reflected beams back for signal processing. The system consists of two key stages, a calibration stage and an application stage. The calibration stage is used to establish a basis for how our scattered wavelengths can be separated in time and distinguished from one another. The application stage comes after the calibration is complete and now the system will be able to detect any targets spectral reflectivity.

The components of these two stages are similar and consist of a wide range of optical elements. The first of which being the TELESTO laser pump which will be used to transmit a high enough power into the silica fiber to cause lasing. The system will also include collimation optics, polarization optics, alignment optics used to orient the laser output perfectly into the fiber. The beam is then shot through a PM-SM silica fiber which is used to induce raman scattering which will be used to split our initial 1064um wavelength into a variety of different wavelengths. Next the output is directed at a diffractive element (calibration stage) or a target (application stage) which scatters beams and reflects their spectral output back into an optical detector. This detector feeds this output to an oscilloscope which is connected to the signal processing systems of the project.

The main goal of the optical subsystem is to direct the high powered beams from the TELESTO pump laser into the silica fiber in order to produce Raman scattering, which when combined with the signal processing side of the project can tell us a target's spectral signature. The design we chose to use was optimized to produce this effect while using cheaper optics than conventional systems while still operating with a higher degree of accuracy.

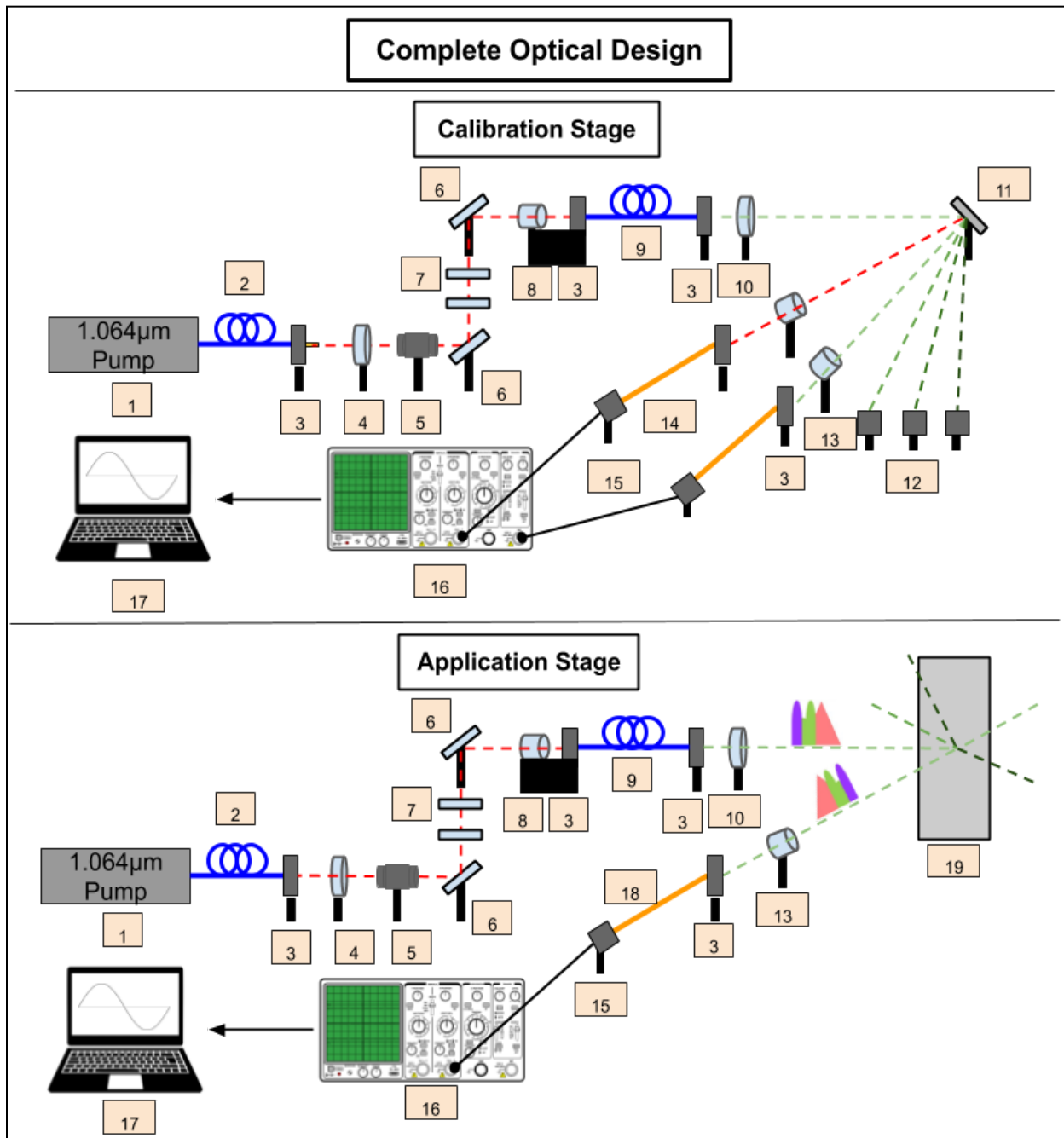

Fig. 31: Raman fiber-laser based object classifier and detector schematic

Optical Design Legend

1	Pump laser controller	11	Diffraction grating
2	1.064 μm wavelength fiber-laser pump	12	Beam stops
3	Fiber collimation and isolation package	13	Focusing lens or microscope objective
4	Collimating Lens (1)	14	2 Fibers with FC/PC connectors
5	Optical isolator	15	Detectors
6	1.064 μm wavelength-reflecting mirrors	16	Oscilloscope/ADC
7	Polarizer and half-wave plate	17	Post-processing unit
8	Microscope objective	18	Single Fiber with FC/PC connector
9	PM-SM fiber	19	Object
10	Collimating lens (2)		

5.3 Telesto Laser

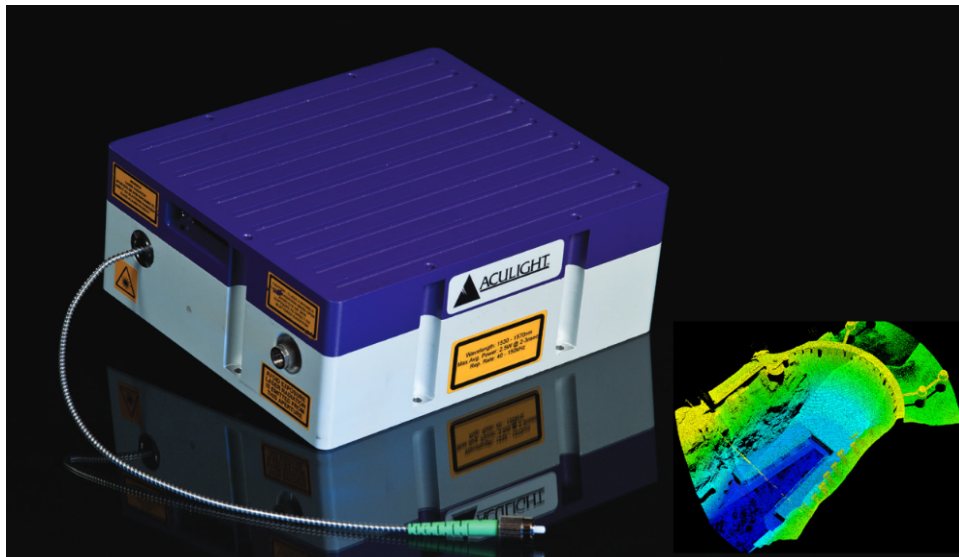

Fig. 32: Lockheed Martin Metelsto fiber-laser system for LADAR applications.

Using a pump laser is paramount to what we are trying to do. Without this high-power class IV laser, it would not be possible to obtain the Raman-based waveforms needed to make our device collect spectral reflectivity measurements. AFRL is loaning us this laser system, Lockheed Martin Telesto, to be able to pump the silica fiber and obtain the multispectral Raman output.

This laser has many promising characteristics for potential LADAR applications, such as high-power, repetition rate, wavelength, and pulse-width. To make our device work properly, Telesto will be operated at specific parameters, which are listed below:

- Wavelength of 1064nm
- Pulse width of 3ns
- Rep rate of 20KHz
- Max peak power 1KW

All which are ideal to make our system work properly and provide our sponsor, AFRL, a good idea as to how a system like this will operate in real life by using a silica fiber as a laser medium.

No other alternatives for this laser system were considered. AFRL originally thought about sending us a “slower” pump laser, possibly with a rep rate of about 10KHz and pulse width of ~10ns, but was currently in use. Therefore, an oscilloscope with a high bandwidth is needed to resolve the shape of the Raman waveforms in the time domain.

The pump laser is connectorized with an FC/APC connector attached. This type of connector has a groove of a specific size on it, which enables the user to attach other components to it or even couple another fiber by using an FC/APC coupler (which will not be used in this project). After the characterization of the laser, it was found that the output was slightly outside the collimator specifications. The collimator was currently a combination of a collimator and polarizer packages. These packages included the Thorlabs SM1PM10 with GL10-C26 Polarizer (1064nm V-coating) and a Thorlabs F810APC-842, 842 nm FC/APC collimation package, NA = 0.25, f = 36.18 mm, AR coated 650nm – 1050nm. With this setup on, the following characteristics were measured:

- Max Average Power: 1.2W (50Khz)
- PRF: 20KHz to 50KHz
- Pulse Width: 3.0nsec (FWHM)
- Beam Size: 3.6mm (D4sigma), 1.85mm(50%peak) (~145mm from collimator aperture)
- Divergence: 0.36mr (D4sigma) (yes 0.36), 0.25mr (50%peak)

These measurements, although not bad, could be improved by using the F810APC-1064 - 1064 nm FC/APC Collimation Package, NA = 0.25, f = 36.60 mm , and an isolator; which was the high hower, 8 mm, 1064 nm, 1/2 waveplate ISO-FRDY-08-1064-W isolator.

Here, we had to stop and think about the parts because these showed that the laser system could have an improvement of output power of 17%. However, this came at a cost. The older isolator had a much greater divergence, but overall smaller spot size out of the laser. The new one would have a much lower divergence angle and better transmission but would make us buy a new isolator due to its larger spot size of 8mm.

After much thought and because we are devising a nonlinear Raman fiber laser that requires the use of higher power densities, we went with the new collimator and isolator. Therefore, the laser will consist of an FC/APC connector with a GL10-C26 prism polarizer, F810APC-1064 collimator, and the ISO-FRDY-08-1064-W isolator. Pictures and additional information is provided in the images below.

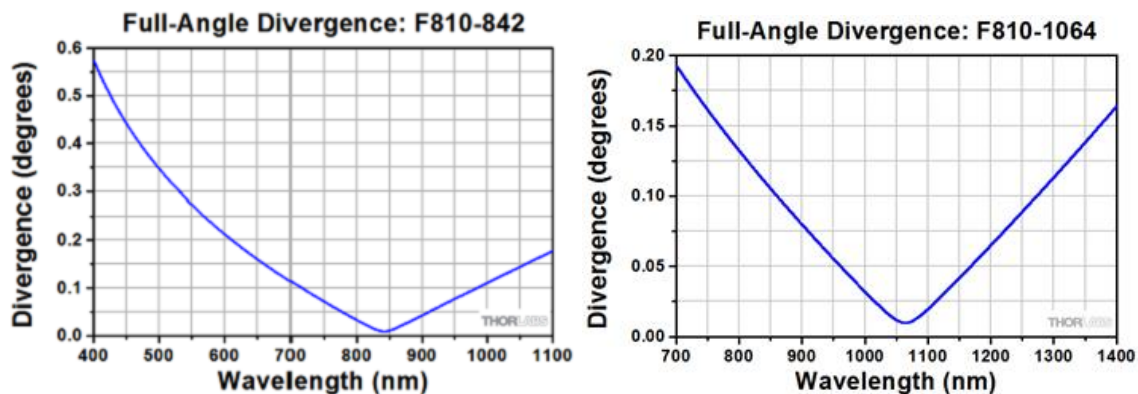

Fig. 33: Divergence differences between the older (left) and the chosen (right) collimation package (more detail in the text above the images).

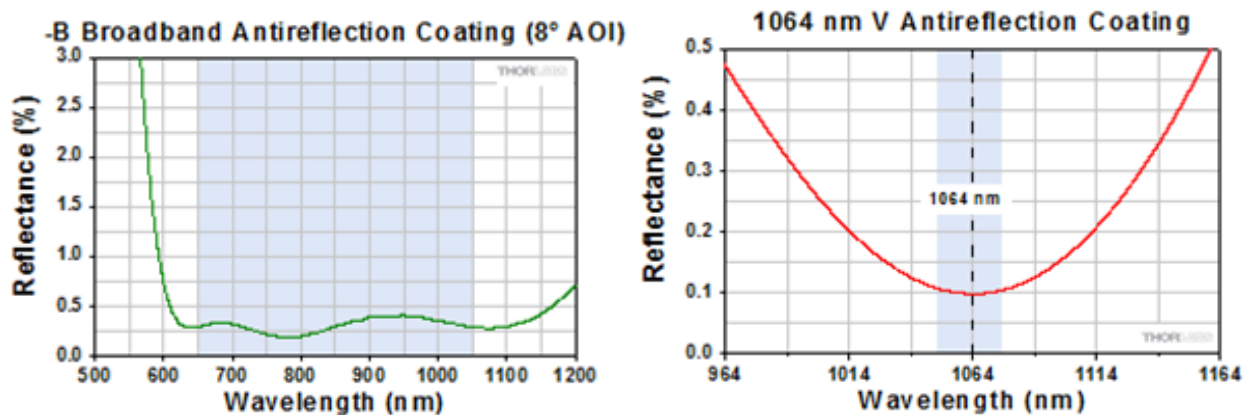

Fig. 34: Reflectance percent of the AR coating present in the collimation packages. Like before, left is older and right is the chosen package. Using the new collimator will improve laser output power by 17% (as verified in the lab).



Fig. 35: ISO-FRDY-08-1064-W optical isolator from Newport.

5.4 Collimation & Alignment Optics

Like any other system involving optics and lasers, such as cameras and laser systems, a misalignment can be detrimental; resulting in light rays that leak out, burning, and no proper gain in laser cavities. These are just a few examples of how important it is to align everything correctly, and that's why we have placed great emphasis on the parts that we are getting and considered for alignment purposes.

To begin the alignment process, and analysis of all parts was done. There is a mixture of free-space and fiber-based lasers in the system, on top of fiber-coupled detectors, thus increasing the difficulty of the task at hand. Since the pump was the first and one of the most important components, a proper way of collimating it and aligning it had to be used.

Discussed in the previous section was the collimation, polarization and isolation packages used by the laser system. Concentrating in the collimation package of the laser again, we will use the F810-1064 package. We discussed it in the previous section because we consider this item to be part of the laser system itself. Nonetheless, it's a collimator so it gets mentioned here. These will provide us with very coherent and slowly diverging light, essential for working in a system like ours. Following this, the laser has to be guided by two silver mirrors. Silver is a highly reflective metal in the visual and IR spectrum. Therefore, Dr. Richardson's group at UCF, CREOL, provided us with two silver mirrors and their holders. These components are both from thorlabs, but due to their age we could not find their model numbers.

Past the polarization controls, the fiber launcher and the fiber itself, is another collimating lens. This is the KBX061 Newport lens. This lens is uncoated, but at this point coating is not needed since enough measures were taken to prevent light from going back into the pump. Beginning with the isolator. Then, the polarizer and half-wave plate. Because all of these will be oriented differently, a minimal amount of power from the pump or Raman signals will go back into the fiber.

Ideally, this lens will be used for collimation. Therefore, the exit of the fiber will be placed at its focal point. This will ensure the rays come out parallel to each other, hit

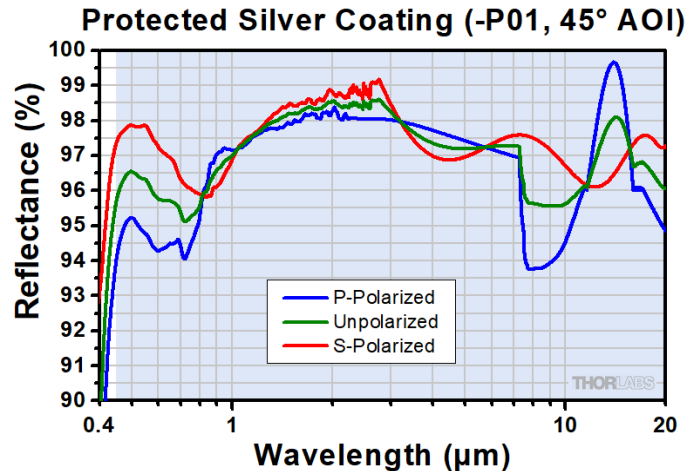

Fig. 36: Conventional Thorlabs silver mirror reflectivity values are two different polarization states and unpolarized light. Excellent reflectivities in the NIR-SWIR reduce the system losses.

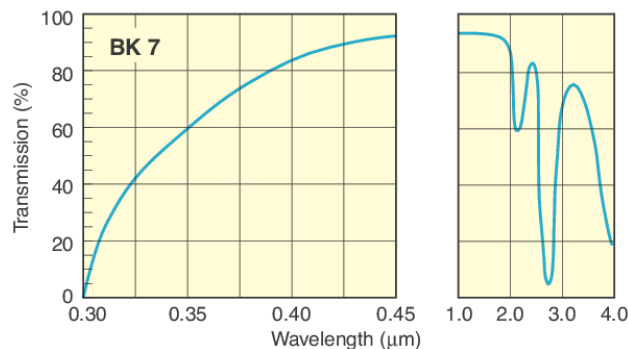

Fig. 37: Transmission information of the KBX061 lens from Newport. High transmission from a wavelength of 1-2microns is ideal. Meaning that reflections normal to the glass are not significant and the lens has minimal loss.

the target and be collected by the detectors. The detectors used are fiber-coupled, which means that lenses must be used, not to collimate but to focus.

Therefore, the exact opposite will be done. The lenses chosen for this part were the Thorlabs A240TM-C lenses. These lenses possess a C-type AR coating (1050-1620nm) and have a large enough aperture to capture as much light as possible to focus onto the multimode fiber.

Other than these components, posts and post holders are also used for alignment purposes. Thorlabs posts available in the laboratory will be used. The way to do alignment with these is correcting the y-position of the optical element and the angular orientation.

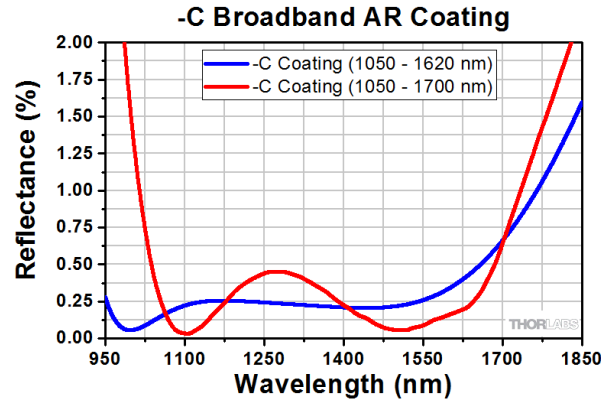

Fig. 38: Multimode fiber coupling lens (A240TM-C) coating reflectances.

It's important to mention the other collimation package and lenses considered for the tasks mentioned above. These lenses were not chosen due to their numerical aperture mismatch with the Raman and MM fibers for the detectors and their lack or wrong type of AR coatings. Initially we didn't want to consider aspheric lenses since these are smaller than 1" in diameter lenses and collect less light. These lenses were:

- F810APC-842 (old collimation package - obsolete)
- A280TM-B
- C240TM-B (its counterpart with the -C coating was chosen)
- A397TM-B
- A260TM-B
- A110TM-B
- KBX070
- KPC034
- KBX064
- KBX052

5.5 Polarization Optics

Polarization plays an integral role in our project. Thanks to the polarization properties of light, we can reduce the length of the fiber by about a factor of six. This is all because there will no longer be any polarization scrambling in the system. Beginning with the pump laser, it contains a small prism polarizer to ensure that the light that comes out of the fiber is linearly polarized.

By inspecting the pump laser, it was found to have a GL10-C26 polarizer from Thorlabs. This has a 1064nm V-coating, which means that barely any 1064nm light is reflected, thus ensuring that the pump laser is safe to use due to no back back reflections possibly occurring (which could ruin the laser).

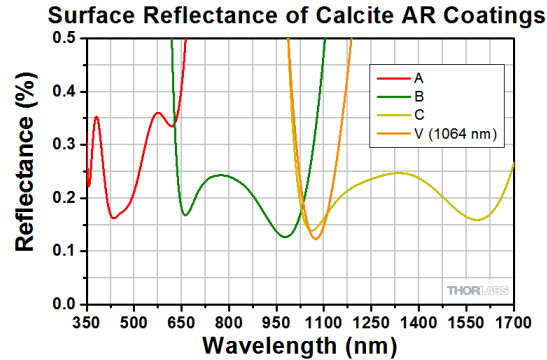

Fig. 39: 1064nm V-coating on the prism polarizer placed at the output of the pump laser.

Moving on to the actual Raman setup, linearly polarized light will come out of the pump. Then, this light will be aligned by the two silver mirrors and then it will encounter two polarization optics along its path. A linear polarizer and a half-wave plate. The first component can be used to attenuate light by rotation, meaning that if the direction of the polarizer does not line up with the laser, it will work as an attenuator. This provides an extra level of control to the power that is sent into the Raman fiber. Then, a polarization controller, which is the half-wave plate, is used. Unlike the polarizer, the half-wave plate just turns the polarization state of light to whatever we want it to be. This is crucial for what we want to do since the fiber that we will be using is polarization-maintaining and we want to make sure we send light through the slow axis.

From Thorlabs, again, the polarizer chosen was the LPNIRB100-MP2 mounted linear polarizer. To hold and be able to rotate this component, the RSP1X15 - Rotation Mount will be used. These will be screwed on together and held by using two posts.



Fig. 40: LPNIRB100-MP2 polarizer (left), AHWP10M-980 half-wave plate (center), and RSP1X15-rotation mount (right). (images from Thorlabs)

Then, to control the polarization that goes into the fiber, as mentioned before, the AHP10M-980 half-wave plate will be used. This half-wave plate and the polarizer are very much alike and controlled in the same way.

5.6 Optical Fibers

Optical fibers are the most crucial components for our device. These are waveguides made of dielectric materials that can carry light and enable us to achieve lasing. The pump laser is (probably) an ytterbium doped fiber that has a center wavelength of 1064nm. As explained in the strategic optical components section, the next optical fiber is a polarization maintaining optical fiber. This fiber has a silica glass core, a silica glass cladding that holds everything together, and two stress rods that induce a birefringence in the core. This induced birefringence generates two new axes, a slow axis that is parallel to the stress rods, and a fast axis that is perpendicular to the rods.

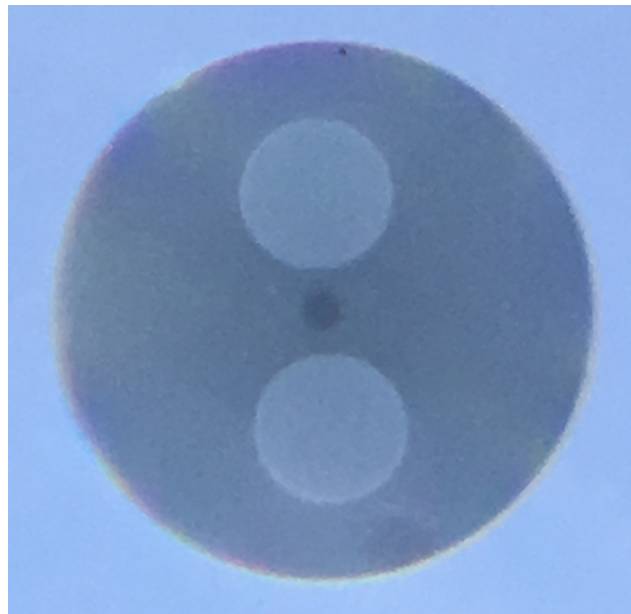

Fig. 41: Panda-style silica PM-SM fiber under a microscope. The darker circle in the center is the core, the two larger brighter circles are the stress rods and the rest is a lower-index silica cladding. Light will be launched into the core with a polarization parallel to the stress rod orientation.

As it can be seen in the microscope figure above, the core is of a very small diameter. This fact, combined with the core and cladding having similar indices means that this fiber is single moded. This part was also discussed in the strategic optics components. The lowest order mode of the fiber has a gaussian profile, similar to a conventional laser output. This type of profile has the majority of the power in the center and exponentially decreases towards the outside. Thus, ensuring that the power density in

the core is high, meaning that the glass will appropriately respond nonlinearly to the light's field and output a set of lower frequency Stokes light waves.

This fact in and of itself is good, but polarization scrambling is an issue. When polarization scrambling occurs, the threshold length needed for SRS is longer. Therefore, by having a PM-SM fiber, we ensure that only 100m is enough to achieve a good Raman output with the added benefit of not having to worry about polarization scrambling.

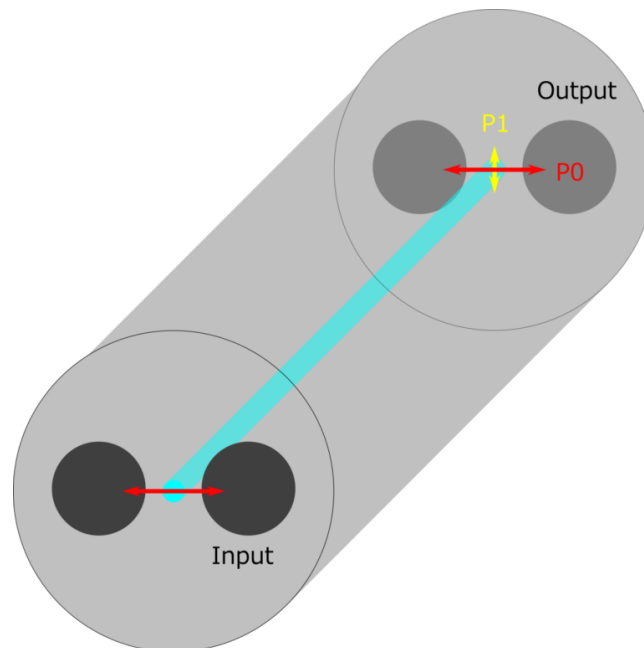

Fig. 42: Polarization maintaining optical fiber showing how an input (red arrows) parallel to the stress rods, which make up the slow axis, maintains its polarization through the fiber until reaching the output. Also, a small yellow orthogonal polarization is shown in the output side, which represents the little bit of power that is transferred to the orthogonal polarization, but it is very minor. (from fiberlabs.com)

The chosen fiber for the job was the PM980-XP. This fiber is PM-SM and will ensure that with 100 meters of it, we will have a good Raman gain and have a nice output. At the beginning, we considered the 1060XP single-mode fiber. For what was discussed at the beginning of this section, a PM fiber ended up being a better choice.

An important consideration for when using optical fibers is a coupling stage. We chose the MBT610D single-mode fiber coupling stage. This stage comes with a V-groove clamp where the fiber can be placed. Since we are going to be placing coreless endcaps on the fiber, a V-groove clamp was a must. The output end of the fiber can just be placed on a raised flat surface that can hold the endcap since what matters is that the output is properly aligned with the lens to collimate the beam.

5.7 Calibration Setup

Since this is not like any other laser system commonly used and we are building it from scratch, it must go through a calibration stage. This calibration stage is paramount to how the device operates since this step is where the shape of the individual wavelengths in time is measured. By individually measuring all waveforms, a complete beam envelope can be constructed by the signal analysis algorithm. By having a built envelope, we create a basis of how the waveforms originally look. This means that when an object is characterized, this same constructed waveform will be visible but with differing amplitudes at each Stokes component. By contrasting the amplitude of the waveforms of the original calibration step with the object is how the spectral reflectivity is determined.

To get each individual wavelength, the output of the silica fiber will be dispersed by using a NIR grating. We have purchased a grating from Thorlabs, specifically the GR25-0310 - ruled Reflective diffraction grating. By using a setup like what is shown below, the pump and each of the Stokes waves produced will be characterized by using an oscilloscope. This oscilloscope will serve as the analog to digital converter (ADC). At this point, we do not yet know the exact model we are going to use, but if we know before the end of the fall semester, we will update this section.

One important factor that must be kept in mind when choosing the right oscilloscope is the sampling and bandwidth. Due to the repetition rate of the pump and the width of each pulse, an oscilloscope with a bandwidth of about 5GHz is the minimum required. Having such bandwidth will enable us to fully resolve the rise of the waveforms and distinguish them if they are very close to each other. It's important to point out too that the signal analysis algorithm can also be used to induce an artificial dispersion to separate the waveforms if they are too close to each other.

In addition to the oscilloscope, high-speed detectors are a must. AFRL will be providing us with the Thorlabs DET08CFC - 5 GHz InGaAs FC/PC-Coupled Photodetector. As the name implies, these are fiberized detectors so we have to collect the light by using two lenses (described in the alignment and collimation section). From Thorlabs, we also purchased two 1m M67L01 - Ø25 µm, 0.10 NA, FC/PC-FC/PC Fiber Patch Cables to use for this.

In summary, during this step, alignment of all optics will be made. This includes polarization alignment and fiber alignment. Then, the power will slowly be turned up to begin the Raman process in the fiber. Following this, SRS will take over and the Stokes waves will be much more visible. After detecting these waveforms, the grating will be

used to separate them all and detect them individually with the oscilloscopes. These will be saved individually to make an overall beam envelope. This beam envelope is

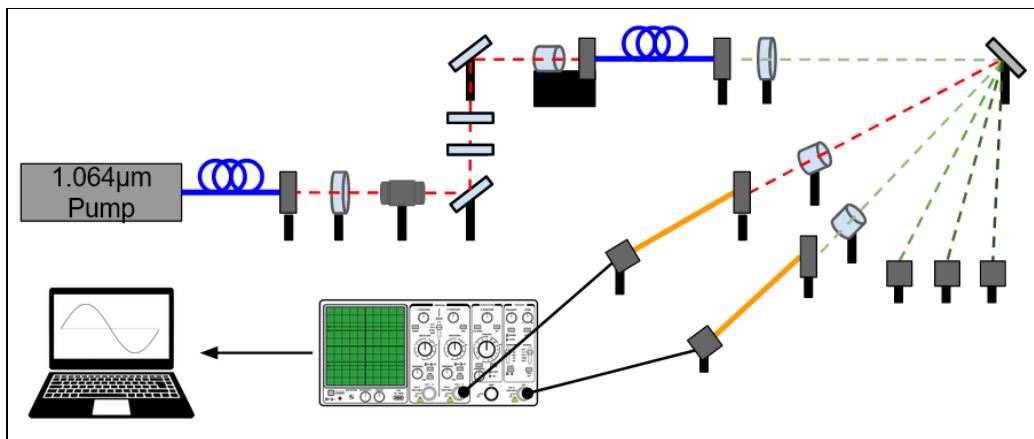

Fig. 43: Raman fiber-laser based object classifier and detector schematic for calibration phase. Each Stokes wavelength will be separately characterized and used to build a beam envelope that will be used in the application stage.

what truly comes out of the fiber when the waves are undispersed. By having this waveform, the signal analysis algorithm has a basic reference waveform that it can compare to so that once an object is placed, the ratio between the original and object-related peaks will yield the spectral reflectivity (this last part applies more to what will be done in the application setup).

5.8 Application Setup

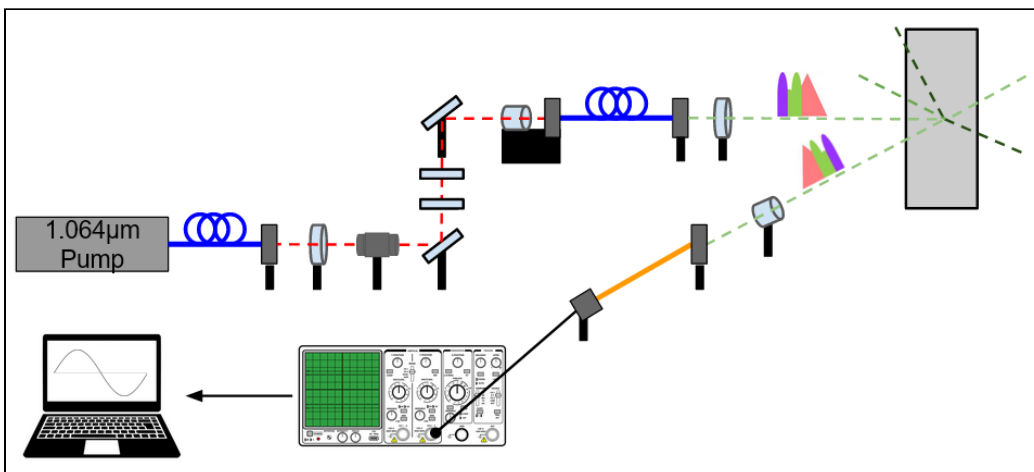

Fig. 44: Raman fiber-laser based object classifier and detector schematic for application stage. Here, the oscilloscope will detect the envelope that will change depending on the target (gray rectangle).

As previously mentioned, after the calibration stage is over, the application setup begins. This is a setup more than a stage since this only describes partially what's occurring. This setup, in comparison to the one in the previous section, replaces the grating by an actual target. Then, all of the detectors are taken out of the system except for one; this is an attractive factor about our system since it only requires one detector to function. In this stage, the oscilloscope will detect the envelope that corresponds to an individual item like soil or a plant. Then, the signal analysis algorithm will compare this waveform with the original and find the spectral reflectivities.

5.9 Electrical Subsystem Overview

The electrical subsystem is important to this project so that we have a way of displaying information to the user without having them have to sit next to the computer/post-processing unit and in an easy to read format. This system consists of 6 components that are connected in a step by step format with the exception of the nine-volt battery.

The first component is the oscilloscope/ADC, this component sends the waveforms in the format of CSV or TXT files to the post-processing unit/computer which is the second component. The post-processing unit/computer then uses signal analysis algorithms to determine range and object classification and then will send this information via Bluetooth 4.0 BLE to the HM-10 Bluetooth module over open space. The HM-10 Bluetooth module is the third component in the block diagram and connects to the custom PCB microcontroller. The fourth component is the 9 volt battery which powers the custom PCB microcontroller which is the fifth component. The custom PCB microcontroller then interprets information from the HM-10 Bluetooth module and then sends commands to the 20x4 LCD which is the sixth and last component of the electrical subsystem. The 20x4 LCD will display the range and possible object classification. This all makes it possible so that a user of the CAD laser system is able to see information about the object that is being detected while not having to be tethered to the post processing unit or the computer.

The main goal of the electrical subsystem is to interpret information that is sent from the post-processing unit/computer to the bluetooth module on the custom PCB over open space so that the microcontroller can display this info on a 20x4 character LCD display. The display will have a backlight and have a green background with black letters. This design is chosen so the user can be away from the computer while still being able to see important information about what the laser is seeing.

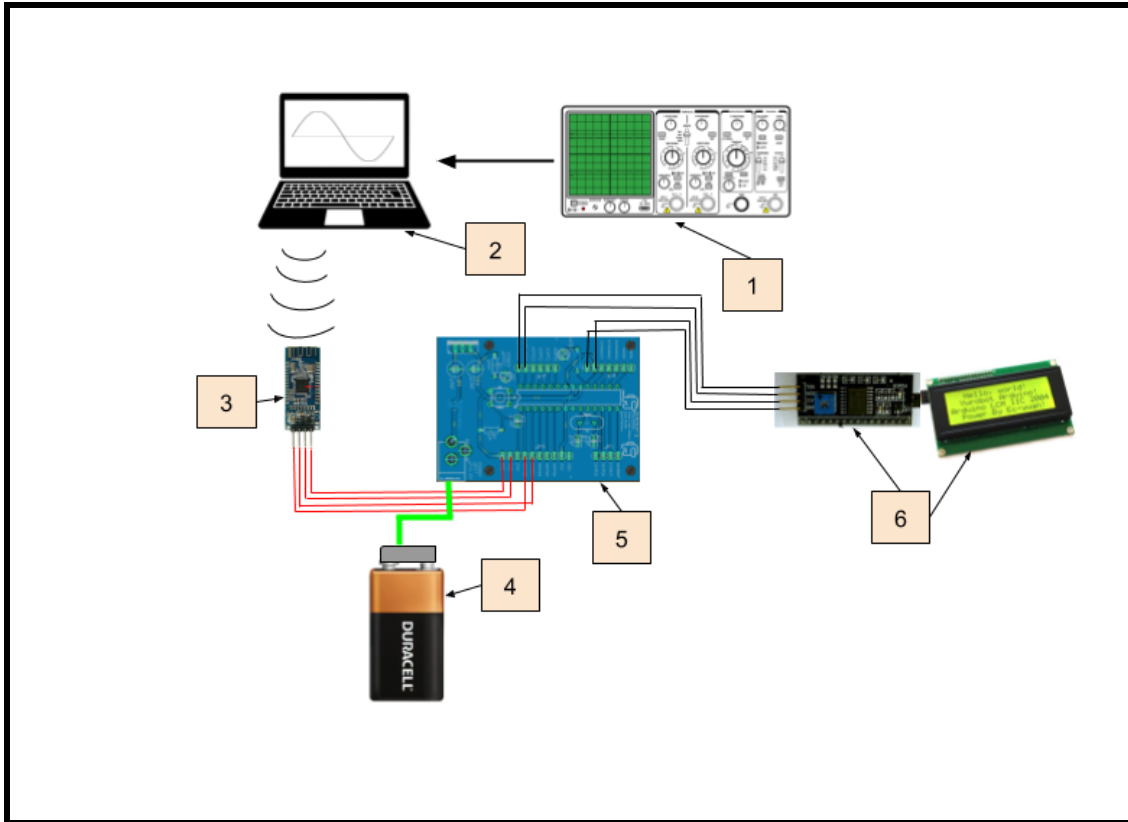

Fig. 45: Block Diagram of the Complete Electrical Subsystem

Component Number	Component Part
1	Oscilloscope/ADC
2	Post-Processing Unit/Computer
3	HM-10 Bluetooth Module
4	9-Volt Battery
5	Custom PCB Microcontroller
6	20x4 LCD with I ² C adapter

Table 3: Table of the Complete Electrical Subsystem Components

5.10 Microcontroller And External Modules

Microcontroller Parts Selection

The role of the microcontroller in our design would be to control a couple devices to give us more information about what is going on with our laser in a neat and easy to read way. The microcontroller will take inputs from a computer through bluetooth, after our waveforms have gone through a series of signal processing algorithms, to output information on an 20x4 LCD display.

The microcontroller will also include LEDs as a form of success checks for different aspects of our laser system. In choosing a microcontroller we keep all this in mind to make the best choice for the project. We also considered how the microcontroller would be programmed, as we are looking for a language we are familiar with and has lots of references online that we can look at. Below we go through each microcontroller that we considered for our design

ATMEL ATmega328

We considered two different microcontrollers and two different SoC (system on chip) for our project. First we considered the ATMEL ATmega 328, this microcontroller is extremely popular, well researched, as well as user friendly as it is a part of the open source arduino platform. A big plus of the ATmega328 is that it is relatively easy to design a custom PCB with. There are many simple reference boards in different PCB design programs as well as guides on PCB design with the arduino platform. Another positive side of the arduino platform is its own arduino coding platform which is similar to C and Java, which we are all familiar with. The platform for the ATmega328 is entirely open source, which means that any code related to the microcontroller is freely available. Because of this, many people choose to utilize it to complete their own projects, making research easy. For example, coding a 7-segment display simply requires finding a library to easily code the display, so that the programmer does not need to individually program each of the LEDs. Things like this make using this platform much more optimal, as parts that would normally be very time-consuming can be found with a simple internet search, and more time can be spent on optimizing the algorithms that make the program work for our specific and unique purposes.

Some of the features of the ATmega328 include a clock speed of 16MHz and a operating voltage of 5V which is a common voltage in the device world. Working with bluetooth and an LCD screen is not too difficult due to many other projects that have

done just that available to look at on the arduino projects website. The ATmega328 is also very low with prices as low as \$2 on sites such as microchip or digikey. A negative aspect of the ATmega328 would be that in our classes we have worked mostly with the texas instruments MSP430 and the arduino platform would be new to us. But all in all, the arduino platform is very promising, and we also have a couple of arduino's in the group to do testing with.

MSP430G2553

The other microcontroller we considered was the MSP430G2553. This is because we worked with this microcontroller across multiple classes and have good experience working with the board. We know the programming language as well as the cost being reasonable at less than a dollar on TI's website. It also runs at a clock of 16MHz and a 3.6V operating input voltage which would be simple to work with. The downsides is the programming language isn't the easiest to work with other devices such as the LCD and bluetooth. Another downside is that the MSP430G2553 isn't as popular as the arduino platform and doesn't have nearly as many reference projects as the massively popular arduino.

Broadcom BCM2711

For system on chips options we considered RaspberryPi's Broadcom BCM2711. Unfortunately Raspberry Pi is not open source when it comes to its hardware so to use this chip we would have to resort to using Raspberry Pi's own compute module. This module would essentially be a raspberry pi in a small board that can be integrated with a custom PCB so that you get the processing power of the Raspberry Pi along with the customization of making your own board. This looked desirable at first because we would be able to do any processing that we would want a computer to do such as signal processing algorithms we plan to do in matlab or python, along with controlling the extra devices. But we felt using the compute module fit with what the requirements of the electrical engineers are for the senior design project at UCF.

Allwinner V3

For the last system on chip we looked at the Allwinner V3. We looked at this chip because there are designs out there using it that are working embedded single board linux systems. These systems also were possible on a 2 layer board which is what we are looking to design. These designs included the BlueBerry Pi which is an open source project available on github and instructables. But there were very few working designs with less than desirable references to work with. There were also many warnings that this project would not be recommended to those with little experience

with PCB design so we looked elsewhere. We will not be considering this option further, as seen by its absence in our table.

Below we use a table to compare the different microcontrollers and the Raspberry Pi compute board processor along with the system on chips.

Using the table and other references, the best fit for our project would be the ATMEL ATmega328. We chose this microcontroller over the others because to implement the BCM2711 we wouldn't fit our design requirements for senior design. While the

Features	ATmega328	MSP430G2553	BCM2711
Temperature Range	-40°C to +125°C	-40°C to +85°C	-25°C to +85°C
Clock Frequency	16MHz	16MHz	1.5GHz
Operating Voltage	5V	3.6V	5V
Memory	32KB flash, 2KB SRAM	16KB flash, 512B SRAM	Up to 8GB
Programmable I/O	23	24	48
Bit Count	8 bit	16 bit	64 bit
Power Consumption	Active mode: 1.5mA at 3V - 4MHz Power-down mode: 1µA at 3V	Active mode: 230 µA at 2.2V - 1MHz Power-down mode: 0.1µA at 3V	Active mode: 1400mA at >2V Power-down mode: 8 µA at >2V
Price	\$2	\$>1	\$25
Part Selected	Selected	Not Selected	Not Selected

Table 4: Comparing prospective microcontrollers

MSP430G2553 would be harder to work with due to lack of reference projects and the programming IDE isn't the easiest to work with. So for ease of design and programming the ATmega328 would be our choice.

5.10.1 The Atmega328p-pu

The Atmega328p-pu is the specific microcontroller that we have decided to go with for designing the custom PCB with our project. It is low-power, 8 bit, and executes instructions on a single clock cycle, which keeps things simple for our programming and designing needs. It also includes 32x8 general purpose working registers, up to 20 MIPS (Million instruction per second) throughput at 20MHz, and an On-chip 2-cycle multiplier. The Atmega328p-pu also includes 32KB of in-system self programmable memory and 2KB SRAM which we will utilize to provide instructions to the microcontroller from the the computer, which then the atmega328p-pu will provide instructions to the external modules.

The ATmega328p-pu also has many serial communication protocols that it can work with including UART, I²C, SPI, and others. It also operates at a voltage of 1.8-5.5V which is within the parameters of the external modules we will be working with which keeps things relatively simple when designing a PCB for our purposes. The ATmega 328p-pu is also a through hole module that is easy to add to a circuit board, which will make it easy to implement within our project. All in all the ATmega328p-pu is perfect for our project because it is a relatively simple microcontroller to work with and to design with, but also includes all the processing power and features that we need for our project.

5.10.2 External Module Parts Selection

There are two external modules that we will be working with for our design. These include a bluetooth module and a display for our custom PCB. First we will go through bluetooth modules. The role of the bluetooth module is to provide a way of communication between our device and others. Bluetooth is a technology designed for exchanging data between two devices over short distances using UHF radio waves. We decided it would be easier to buy a compatible bluetooth module than design a whole new bluetooth module integrated with our board. The important thing we want our bluetooth module to do is to be able to communicate between a computer and our custom PCB. We want to be able to tell the custom PCB what to display on an LCD screen based on results found on the computer wirelessly after doing signal analysis on matlab or python.

When choosing a bluetooth module for this purpose we considered ease of use and voltage requirements of the different modules. We ended up considering two different bluetooth modules, the HM-10 and the HC-05. If our computer does not have bluetooth capability we will be adding a dongle that is bluetooth compatible with our chosen module. The reasoning behind choosing bluetooth to communicate between the computer and our custom PCB is because we want our device to be able to display important information while also being mobile so that the user is not required to be

next to the computer to see this information. Below are the bluetooth modules that we have considered for this project.

HC-05 Bluetooth Module

The first module we considered was the HC-05 bluetooth module. This module is compatible with bluetooth V2.0 and uses the UART serial communication protocol. Has 8 pins including an enable key at pin 1 which is a toggle between data mode and AT command mode, this pin is by default at data mode. At pin 2 we have a Vcc which powers the module which should be connected to a +5V supply voltage. Pin 3 is the ground pin which should be connected to a system ground. Pin 4 would be the TX transmitter that transmits serial data, everything that is received over bluetooth will be sent to the device as serial data. Pin 5 would be the RX receiver, the purpose of this pin is to broadcast serial data over bluetooth. Pin 6 is the state pin which is connected to an LED on the module, this is used as feedback for bluetooth success. Pin 7 is the LED, this indicates the status of the bluetooth module. The LED blinks once every 2 seconds if in command mode, repeated blinking means the module is waiting for the connection in data mode, and lastly blinking twice in one second means that connection is successful in data mode. Pin 8 is the button which toggles the enable pin which controls whether the module is in data or command mode. All this makes the device relatively easy to use but it is older technology and consumes more power with an operative voltage of 4V to 6V and a operating current of 30mA.

HM-10 Bluetooth Module

The second module we considered was the HM-10 bluetooth module. This module is compatible with bluetooth V4.0 and uses the UART serial communication protocol. Bluetooth V4.0 outperforms bluetooth V2.0 in speed, throughput and range. This board has 34 pins but I will talk about the 4 important pins which are connected to our custom PCB. Pin 12 is the VCC which has an operating voltage of 3.3V to 6V. Pin 1 would be the UART_TX which is used to transmit information via bluetooth. Pin 2 would be the UART_RX which is used to receive information via bluetooth. And lastly pin 13 is the ground pin which should connect to the system ground. This bluetooth module also includes an LED indicator for data and command modes. The HM-10 also includes a BLE chip which is bluetooth low energy. This chip allows the system to operate with low power draw and also includes a low power mode. We compare the features of the two modules in the table below and afterwards make a decision based on the pros and cons of each device.

Features	HC-05 Bluetooth Module	HM-10 Bluetooth Module
Bluetooth Version	V2.0	V4.0

Data Rate	3 Mbps	24 Mbps
Power Consumption	30mA	0.4 - 1.5 mA
Distance Range	10 Meters	100 Meters
Manufacturer	HiLetgo	DSD TECH
Cost	\$8	\$10
Part Selection	Not Selected	Selected

Table 5: Comparing prospective bluetooth modules

Using the table and other references, the best bluetooth module we decided that the HM-10 would be the best module to work with. The reasons being that the HM-10 includes more features while consuming less power for only \$2 dollars more. The HM-10 also has 90 more meters of range in open space and can send 21 more Mbps of data than the HC-05.

Next we will go through the part selection process for the display we want to connect to our device. We will also discuss the use of LEDs with our project. The role of the display is to essentially display information we get from the sensors and the computer in an easy to read format. The display needs to be able to show the range and material composition of the object that we are directing our laser at. The display will be controlled directly by the microcontroller on our custom PCB. In choosing a display we will decide based on different factors that are important to the project. These factors include ease of use, power draw, and how many characters and numbers can be displayed. We looked at two different displays that are compatible with our project, a 16x2 LCD module and a 128x64 OLED LCD display. Below we go through the different aspects of each display. Our group has some LEDs that we will use for the success check and we have no need to buy new ones.

The 16x2 and the 20x4 LCD module with I²C integrated in the system are as simple as it gets, they use I2C protocol to reduce occupation of I/O ports that we need for our projects. Has dimensions 80mm x 35mm x 11mm, is compatible with arduino, and includes a potentiometer to adjust the backlight. It also has a voltage requirement of

Feature	16x2 LCD module	20x4 LCD Module	128x64 OLED display
Voltage Requirement	5V	5V	3-5V
Character Limit	32	80	Limited by pixels

I2C	Yes with adapter	Yes with Adapter	Yes, embedded
Dimensions	80x35 mm	60x99 mm	23x23 mm
Manufacturer	DAOKI	HiLetgo	IZOKEE
Cost	\$8	\$13	\$8
Part Selection	Not Selected	Selected	Not Selected

Table 6: Comparing prospective display modules

5V. The 128x64 OLED display also uses I2C and has dimensions 23mm x 23mm. It is also compatible with arduino and has a 3V to 5V voltage requirement. Below is a table comparing modules. After reviewing the pros and cons of each device we initially decided to go with the 128x64 OLED display because of its versatility, but after looking at the dimensions we decided that it is too small and would be hard to read. We then decided to go with the 20x4 LCD module because of its size and how many characters we could add to it and the fact that it is the same price as the smaller 16x2 LCD module.

5.10.3 Selected External Modules

The HM-10 bluetooth module made by DSD Tech is the specific bluetooth module we have decided to use with our project. The HM-10 uses Bluetooth version 4.0 BLE which is a very low power consumption version of bluetooth that works by sending packets of data at a time instead of sending a constant stream of data like other bluetooth versions. The HM-10 also uses the UART serial communication protocol. The working frequency is 2.4GHz. The HM-10 bluetooth module also is able to work up to 100 meters as opposed to the HC-05 which only works up to 10 meters.

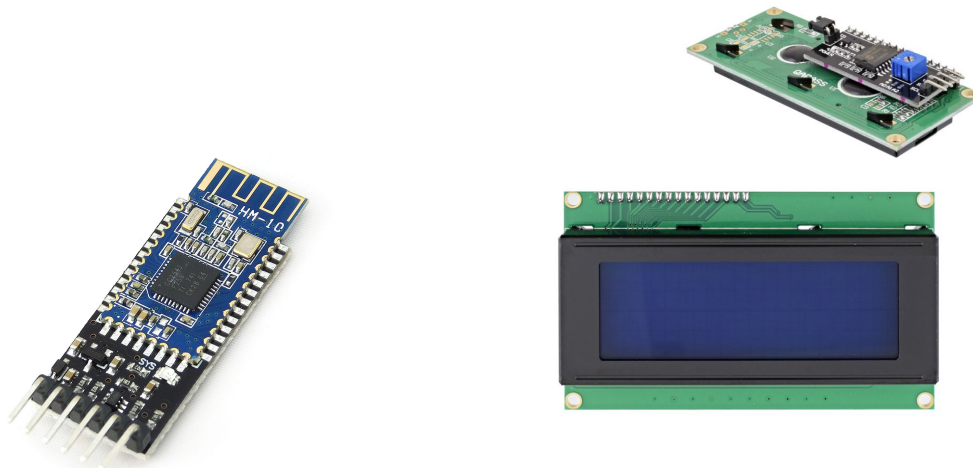

Fig. 46: The HM-10 bluetooth module (Left) and the 20x4 LCD display with I2C adapter (Right)

The 20x4 LCD 2004 with an I²C adapter is the display we have decided to use for our project. It includes an LCD display with an adjustable LED back light. With 20 characters to four different lines it has a total of 80 characters available to use. It has an operating voltage of five volts and only requires VCC, GND to power it, and the I²C wires SDA and SCL to control it.

5.11 Hardware Design (15-20)

A great many theories and technologies are required if one hopes to create their own custom PCB microcontroller. To begin the process of creating one requires us to decide what program to design our PCB with. There are many PCB designing softwares out there, but to narrow it down we first looked at the free ones KiCad and the student version of Autodesk EAGLE. KiCad has many cool features like the 3D PCB viewer but we decided to go with Autodesk EAGLE because it is what we have worked with in past classes and there are many tutorials out there to help us learn more about PCB design.

In Autodesk EAGLE we started by creating a project and the schematic. The only libraries that we used were the EAGLE library and the sparkfun library which we sourced most of our major components. The reason behind using the sparkfun library is because it adds a lot of components that include footprints, and are easily found on manufacturing websites. After adding each component we started connecting each component. We started with the power module, then the microcontroller module, then lastly the headers. Then we moved on and created the board layout, aiming for simplicity. We were able to design a 1 layer board with a single copper pour as a grounding plane.

The first step in designing a PCB is to build a schematic including all the parts that are going to be included in the PCB design. Another important concept is to have the schematic be in a format that is easy to look and for that we have split up the design into three major sections including the power module, the microcontroller module and headers which we can see below in the full schematic of our custom PCB microcontroller. To build the different modules we used the EAGLE and SparkFun libraries. First we will go through the power module and its parts. Below is the full schematic for our custom PCB microcontroller.

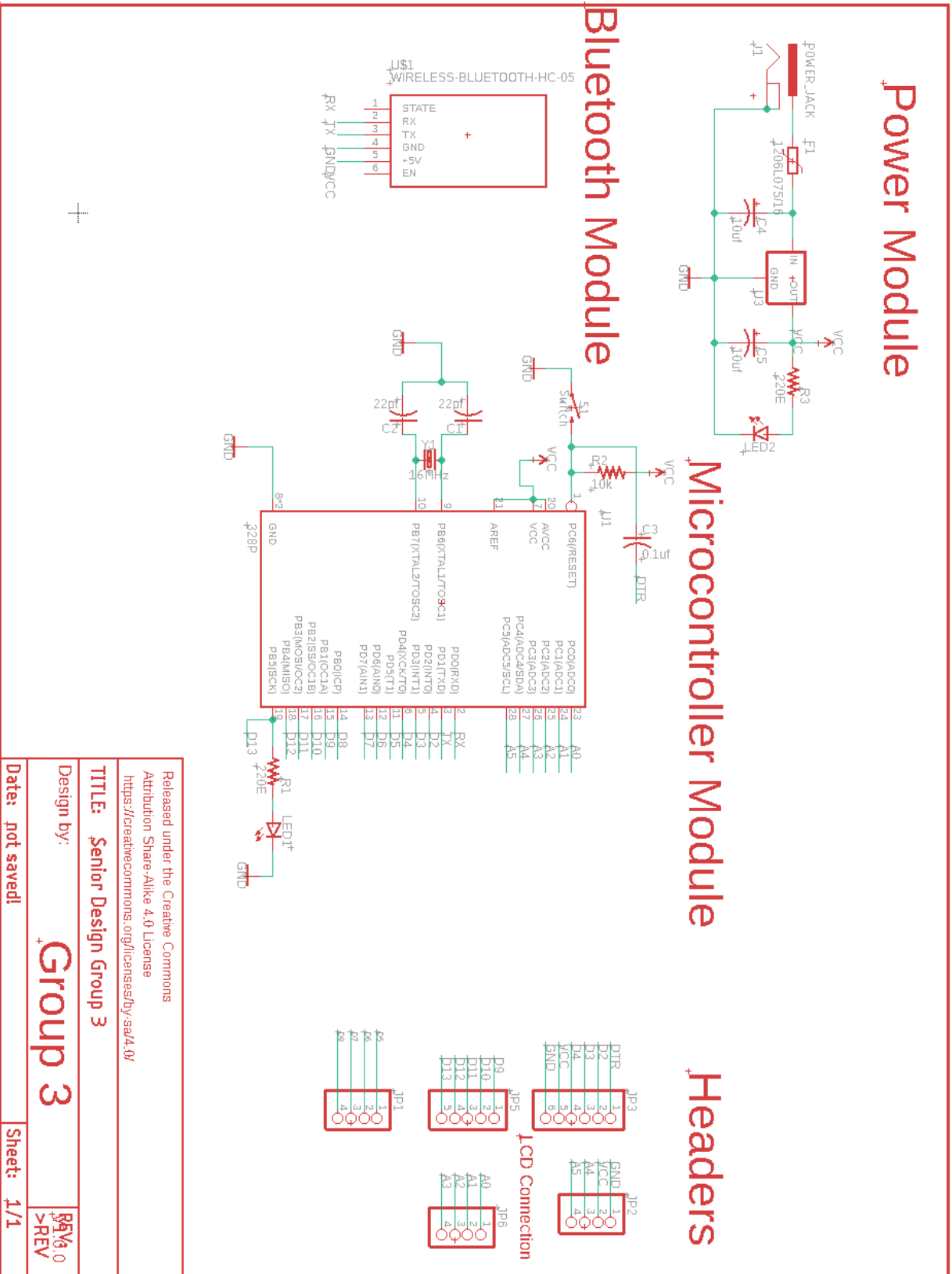

Fig. 47: Schematic of the full system

Released under the Creative Commons Attribution Share-Alike 4.0 License
<https://creativecommons.org/licenses/by-sa/4.0/>

TITLE: Senior Design Group 3

Design by: **Group 3**

Date: not saved!

Sheet: 1/1

Rev: 0
>REV

5.11.1 Power System

The power system includes more than that is shown in the schematic including a 9 volt battery and a cord that connects it to the power jack in our schematic. This power system is what will bring our whole custom PCB and the external modules to life, and is very vital that it works perfectly. It is essentially the heart of the PCB. Below is a figure showing the schematic of the power module in a closer view.

Power Module

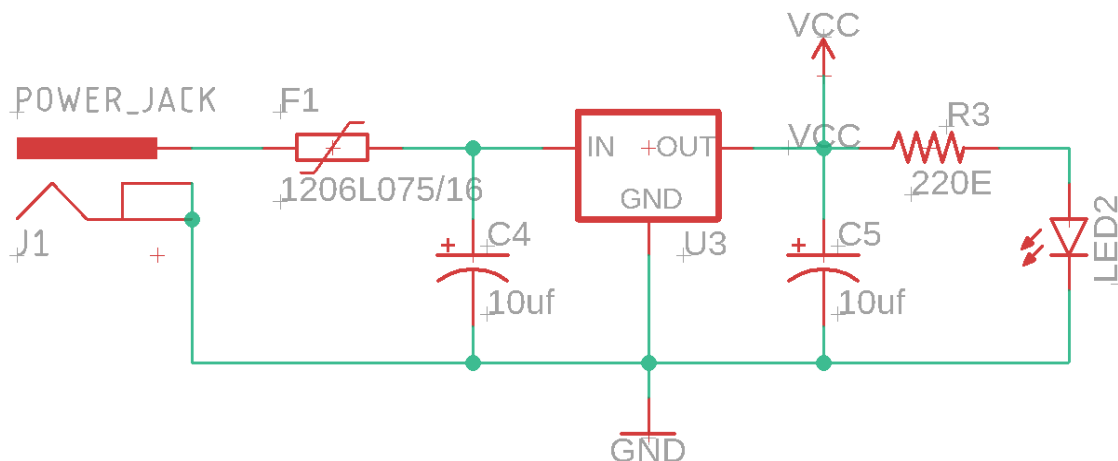

Fig. 48: Schematic of the Power Module

In the power module of the schematic we can see a power jack component that sends voltage to a fuse and shorts out the bottom of the component to ground. This ground is also connected to multiple points in the custom PCB microcontroller such as to the ATmega328p-pu ground pin and to multiple points on the headers. The fuse protects the whole system from taking on incredibly high voltages and frying all the more delicate parts like the microcontroller unit. We shouldn't see incredibly high voltages in our project seeing as we plan on using a 9 volt battery but it is better to be safe than sorry with our device seeing as a fuse is an inexpensive part and it easy to integrate into our schematic. It would be very costly in time and resources if our custom PCB was fried. The next important part of our power module is the voltage regulator which we used a 7805 voltage regulator. This voltage regulator makes sure that the voltage coming out is always 5 volts which is what all the devices in our PCB are set to work

with. We have also included two 10uF capacitors so that the DC signal that is fed to the voltage regulator is clean and has no AC ripple which is what C4 is for and C5 improves transient response. We can see the output goes directly to VCC and to an LED that will indicate that the custom PCB is being fed power successfully. Below we can see the power module more closely. Below we can see the power module converted to PCB layout which we will go over later in this document.

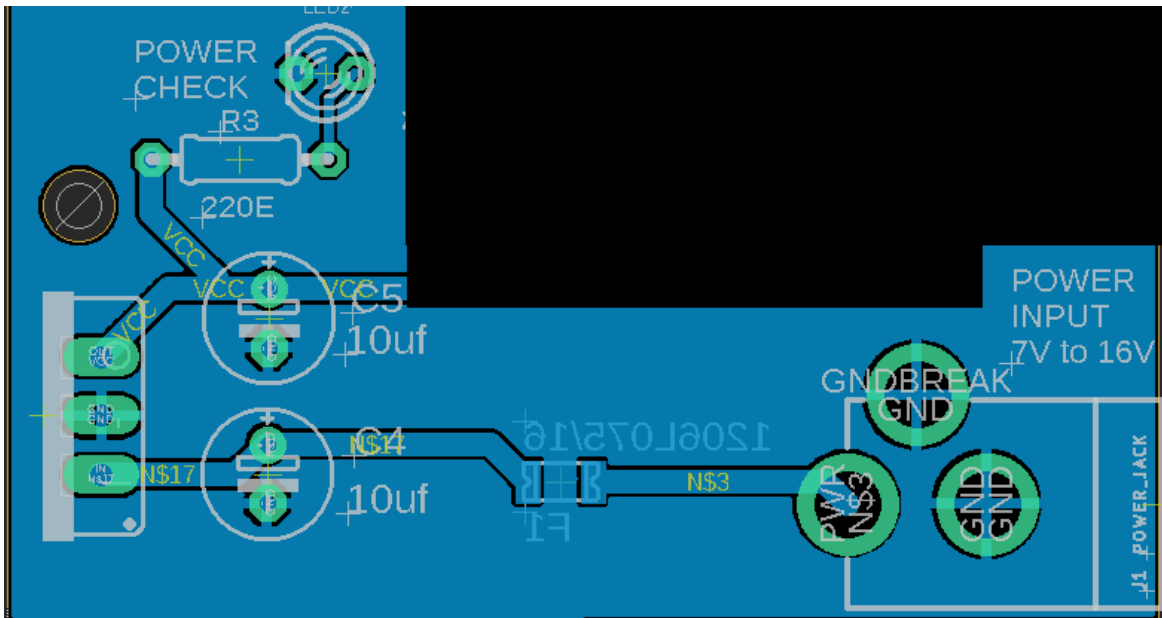

Fig. 49: Power Module Layout on PCB

5.11.2 Microcontroller Module

The microcontroller module is the brain of our custom PCB. It will receive code from the computer and from there will control the external modules through the headers in our device. It also includes an external clock along with accompanying capacitors. It also includes a switch system that is used to program the ATmega328p-pu microcontroller. To design the microcontroller module in eagle we went through many tutorials online that show how to work with microcontrollers and specifically the ATmega328p-pu. Below is a closer look at the microcontroller module of which we will go through all the different components that go into it.

The microcontroller module features the ATmega328-pu which is through hole and comes with many pinouts which we will now go through. To start the ATmega includes a PC6 pin at the top left of the schematic which is used as a RESET pin that cycles the power when shorted. In the schematic I have included a switch which does the shorting and an input of VCC which we included a 10k resistor because the PC6/RESET pin does not require a large amount of current. The PC6 pin also connects

to the DTR line which is used in programming the ATmega328p-pu because the power needs to be cycled when programming the board. The DTR line is also connected to a header.

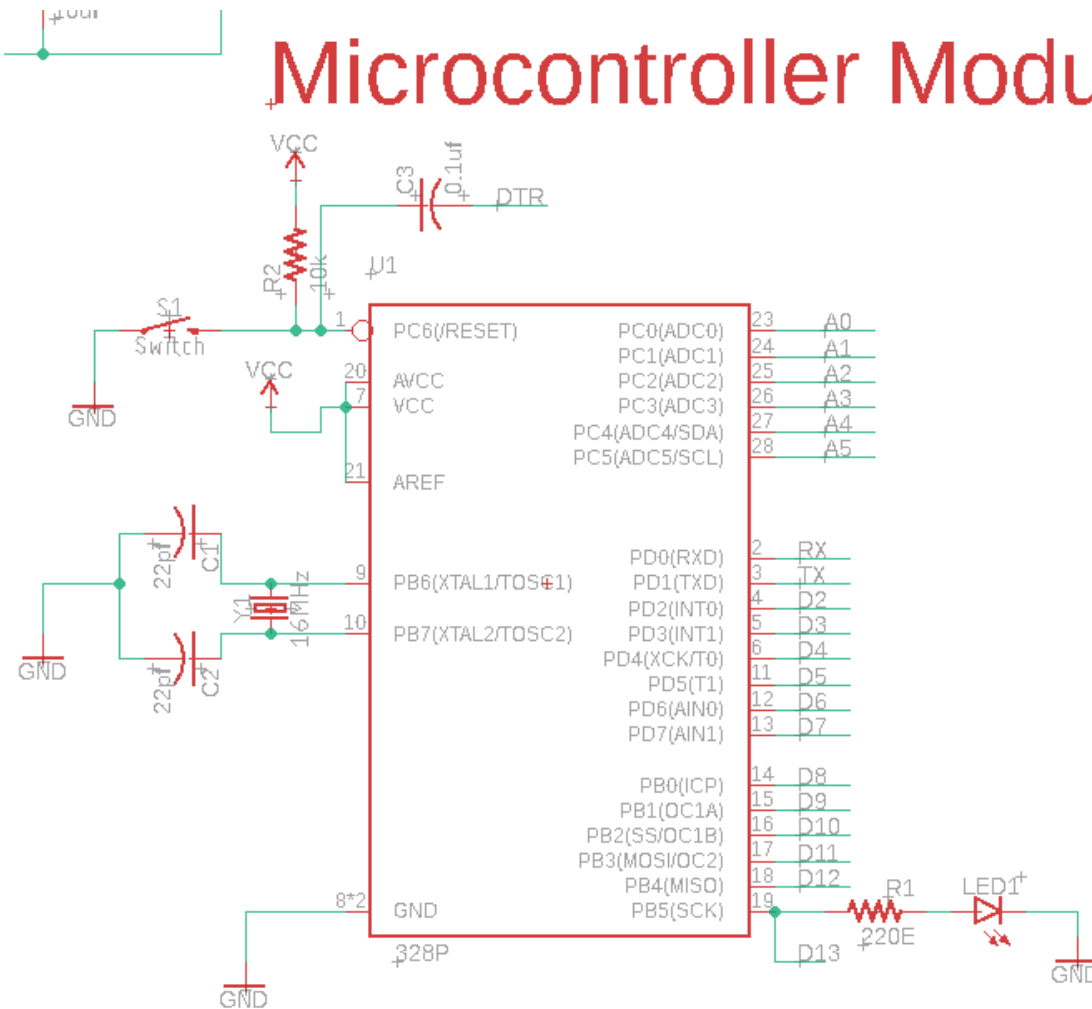

Fig. 50: Schematic of the Microcontroller Module

Below the RESET pin is the AVCC, VCC, and the AREF pins. We connected all these pins to VCC. AVCC represents the voltage supply pin for the Analog to Digital (A/D) converter at PC3:0 and ADC7:6. VCC represents the digital voltage supply that powers the ATmega328p-pu, and AREF is the analog reference pin for the analog to digital converter. Below that are the pins that connect to the clock which include PB6 and PB7. PB6 is used as the input for the inverting oscillating amplifier and the input for the internal clock operating circuit. PB7 is used as the output for the inverting oscillating amplifier. This is because we are using a 16 MHz crystal oscillator as the clock source because it is highly accurate, and consistent. The 16 MHz crystal oscillator connects to

two 22pF capacitors that are in parallel and then go to ground. A crystal oscillator cannot start if the crystal and the capacitors do not fully produce a phase shift of 180 degrees back to the input of the inverter inside the ATmega328p-pu. This is because the inverter produces an effectively 180 degree phase shift, so for the oscillation to occur it requires that the two capacitors and the crystal must form an extra 180 degree phase shift along with an overall voltage gain of greater than one. The two 22pF are chosen based on a formula shown below:

$$C_L = \frac{C_1 \times C_2}{C_1 + C_2} + C_s$$

Fig. 51: Formula for load capacitance where C1 and C2 are the parallel capacitors and CS is the stray capacitance of the circuit

With CL equal to 16pF for our chosen oscillating crystal we found the capacitor values that we needed to be 22pF predicting stray capacitance to be around 5 pF to be safe. The capacitors are then connected to ground. If our oscillator does not work the way we want it to, we will choose a new 16MHz crystal and recalculate the load capacitance and pick new capacitors. The spot that the crystal oscillator and the capacitors are placed in the custom microcontroller PCB make it easy to replace them. Below that is the ground pin for the ATmega328p-pu which we connect directly to ground.

In the top right of the microcontroller we have the port C pins of which there are six. Each of these pins are connected to a header. Port C is a 7-bit bi-directional Input/Output port with internal pullup resistors which are selected for each bit. All pins in port C have symmetrical drive characteristics with both high sink and source capability. This means each of these pins can drive a load up to VCC or low towards ground, along with being able to support low impedance load. The port C pins also permit a high amount of current (40mA) to take as input or output. If these pins are set as inputs and are externally pulled low they will source current if the pull-up resistors

Port Pin	Alternate Function Port C
PC6	RESET (Reset pin) PCINT14 (Pin Change Interrupt 14)
PC5	ADC5 (ADC Input Channel 5) SCL (2-wire Serial Bus Clock Line) PCINT13 (Pin Change Interrupt 13)
PC4	ADC4 (ADC Input Channel 4) SDA (2-wire Serial Bus Data Input/Output Line)

	PCINT12 (Pin Change Interrupt 12)
PC3	ADC3 (ADC Input Channel 3) PCINT11 (Pin Change Interrupt 11)
PC2	ADC2 (ADC Input Channel 2) PCINT10 (Pin Change Interrupt 10)
PC1	ADC1 (ADC Input Channel 1) PCINT9 (Pin Change Interrupt 9)
PC0	ADC0 (ADC Input Channel 0) PCINT8 (Pin Change Interrupt 8)

Table 7: Table of the alternate functions of port C of the ATmega328p-pu from the data sheet

are activated. Port C pins are also tri-stated when a reset condition becomes active, such as when the reset button is pressed, even if the clock is not running. The most useful pins in port C for our project would be the RESET pin which we will use to program the device, the SCL and SDA which will help control the external modules such as the 20x4 LCD display and the bluetooth module. The alternative functions of each of these pins are shown in a table below.

The next set of pins we will talk about are the port D pins which are below the port C pins. Port D is an 8-bit bi-directional Input/Output port with internal pull-up resistors that are selected for each bit similar to port C. The port D pins also have symmetrical drive characteristics with both high sink and source capability. Port D pins when working as inputs and are pulled low externally will also source current if the pull-up resistors are active. Port D pins are also tri-stated when a reset condition becomes active. Port D pins if used in our project will be used as digital input/outputs along with

Port Pin	Alternate Function Port D
PD7	AIN1 (Analog Comparator Negative Input) PCINT23 (Pin Change Interrupt 23)
PD6	AIN0 (Analog Comparator Positive Input) OC0A (Timer/Counter0 Output Compare Match A Output) PCINT22 (Pin Change Interrupt 22)
PD5	T1 (Timer/Counter 1 External Counter Input) OC0B (Timer/Counter0 Output Compare Match B Output) PCINT21 (Pin Change Interrupt 21)

PD4	XCK (USART External Clock Input/Output) T0 (Timer/Counter 0 External Counter Input) PCINT20 (Pin Change Interrupt 20)
PD3	INT1 (External Interrupt 1 Input) OC2B (Timer/Counter2 Output Compare Match B Output) PCINT19 (Pin Change Interrupt 19)
PD2	INT0 (External Interrupt 0 Input) PCINT18 (Pin Change Interrupt 18)
PD1	TXD (USART Output Pin) PCINT17 (Pin Change Interrupt 17)
PD0	RXD (USART Input Pin) PCINT16 (Pin Change Interrupt 16)

Table 8: Table of the alternate functions of port D in the ATmega328p-pu from the data sheet

the TXD and RXD pins for our external modules, such as bluetooth and the 20x4 display. Furthermore, port D pins include alternate functions like the port C pins which are shown below in a table.

The last set of pins we will talk about below the port D pins are the port B pins. These pins function similarly as the port D pins as they are also an 8-bit bi-directional Input/Output port with internal pull-up resistors that are selected. They also have symmetrical drive characteristics with both high sink and source capability. Port B pins when working as inputs and are pulled low externally will also source current if the pull-up resistors are active. Port B pins are also tri-stated when a reset condition becomes active. The major differences are that PB6 can be used as an input for an inverting oscillator amplifier and input to the internal clock operating circuit and PB7 can be used as an output from the inverting oscillator amplifier. The important pins that we will be using for our project would be the timer oscillator pins and the Furthermore, port B pins include alternate functions like the port C pins which are shown below in a table.

Port Pin	Alternate Function Port B
PB7	XTAL2 (Chip Clock Oscillator pin 2) TOSC2 (Timer Oscillator pin 2) PCINT7 (Pin Change Interrupt 7)

PB6	XTAL1 (Chip Clock Oscillator pin 1 or External clock input) TOSC1 (Timer Oscillator pin 1) PCINT6 (Pin Change Interrupt 6)
PB5	SCK (SPI Bus Master clock Input) PCINT5 (Pin Change Interrupt 5)
PB4	MISO (SPI Bus Master Input/Slave Output) PCINT4 (Pin Change Interrupt 4)
PB3	MOSI (SPI Bus Master Output/Slave Input) OC2A (Timer/Counter2 Output Compare Match A Output) PCINT3 (Pin Change Interrupt 3)
PB2	SS (SPI Bus Master Slave select) OC1B (Timer/Counter1 Output Compare Match B Output) PCINT2 (Pin Change Interrupt 2)
PB1	OC1A (Timer/Counter1 Output Compare Match A Output) PCINT1 (Pin Change Interrupt 1) PCINT8 (Pin Change Interrupt 8)
PB0	ICP1 (Timer/Counter1 Input Capture Input) CLKO (Divided System Clock Output) PCINT0 (Pin Change Interrupt 0)

Table 9: Table of the alternate functions of port B in the ATmega328p-pu from the data sheet

At the bottom right of the ATmega328p-pu we also included a LED and a connected resistor of value 220 Ohm that is connected to pin PB5. We plan to use this LED as a success indicator and will be colored green accordingly. This concludes all the pins that are included in the ATmega328p-pu.

Each pin is useful for different purposes, but the most important pins for our design will be the pins that connect to the UART and I2C serial communication protocol compliant devices with which the UART protocol compliant device uses the TX and RX pins which are located at PD1 and PD0 on our custom PCB microcontroller which shown the board layout is shown in section 6.3, along with VCC and GND. The I2C serial communication protocol compliant device will use the SDA and the SCL pins which are located at PC4 and PC5 on our custom PCB microcontroller. Below is a closer look at what the microcontroller module would look like on a PCB. The blank blue space covers the rest of the PCB parts so we can have a better look at the microcontroller module specifically.

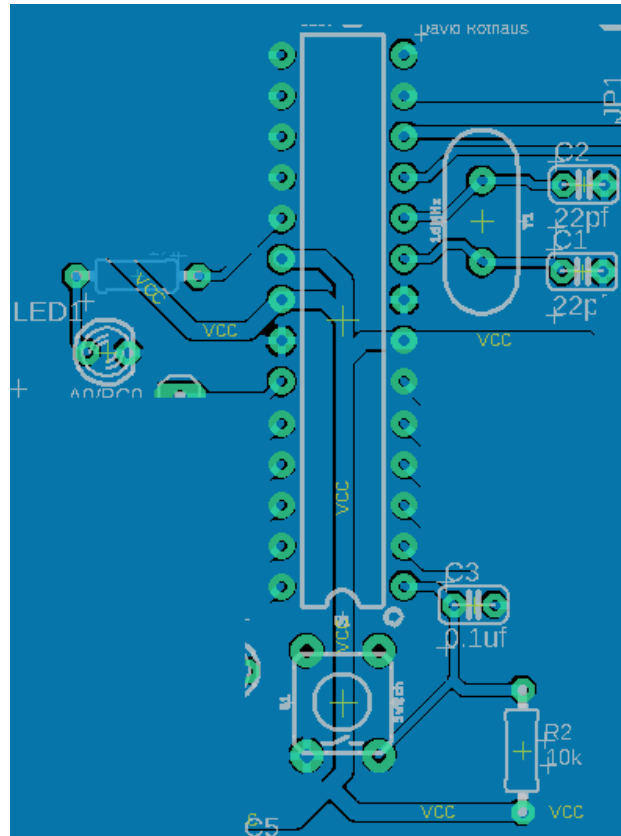

Fig. 53: Microcontroller Module Layout on PCB

Next we will discuss the headers that most of the pins are directly connected to. Below is a closer look at the headers in the schematic of our custom PCB microcontroller.

5.11.3 Headers

The last main component of our schematic is the headers. The headers provide an easy way to connect external modules to the custom PCB microcontroller. We specifically chose header sizes and what pins to connect to the headers so that when we moved to the next step in designing the PCB which is the board layout, we will have an easy time connecting the headers to the pinouts of the ATmega328p-pu. This is so that our custom PCB microcontroller can be routed in a way that is not complex. We included a 1x6, a 1x10, a 1x7, and a 1x4 header. The 1x6 header labeled JP2 connects to the PC0:5 pins on the microcontroller. The lines that connect to this header are labeled A0:5 to designate that these pins can be used as analog to digital converters along with being digital input/outputs. The next header labeled JP5 is sized at 1x10. This header includes connections to two grounds and two VCC pins to power external modules. Also included on this header are the pins PD0:7 we labeled the connections to PD0 and PD1 as RX and TX respectively because these will be important

connections if using an I²C device of which we plan to do so. In this header we also include a connection to PC6 labeled DTR which will be used for programming purposes. The rest of the pins are designated as D2:7 because if used they will be used as digital input/outputs. The 1x7 header labeled JP4 includes connections to VCC and ground to power an external module. This header also includes connections to pins PB1:5 these connections are labeled as D9:13 because if used they will be used as digital inputs/outputs. The last header is labeled JP1 is a 1x4 header and connects to pins PD5:7 and PB0. These pins if used will be used as digital input/outputs.

Headers

ile

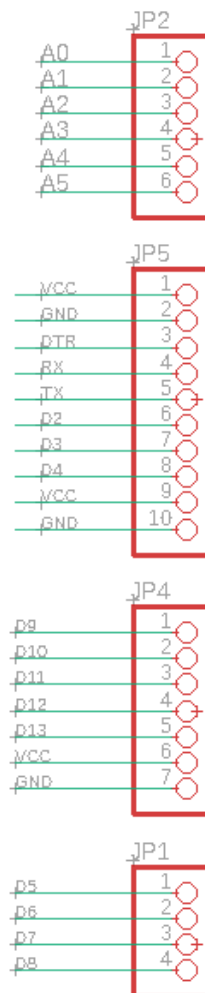

Fig. 54: Schematic of the Headers

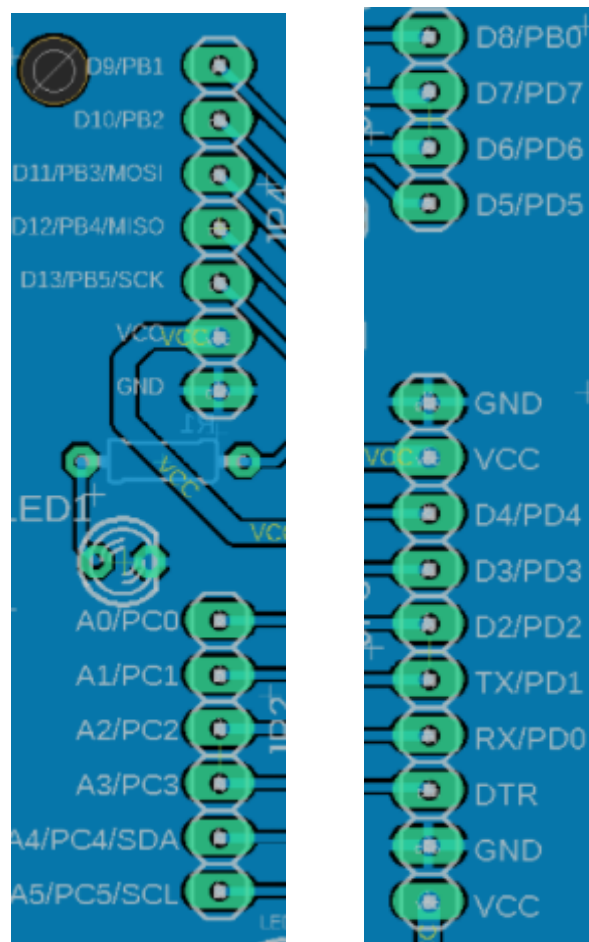

Fig. 55: Headers on our custom microcontroller PCB which are labeled via the silk screen

There are many reasons behind using headers instead of soldering the external components directly to the board, because that was an option considered so to reduce size and the amount of wires coming from the board. The first reason is the versatility of using headers. Headers let us use the different pins attached to the microcontroller in a fashion that is less permanent than using solder to connect external modules to the board. Because we plan to use a usb to I²C module to do the programming of the custom PCB microcontroller; if we soldered the external components we would have to either add an extra header for the programming module or solder the programming module to the board also which leads us to the second reason we are not soldering the external modules to the board: Bulkiness. If all the external components are soldered to the board it would require making the board much larger to be able to accommodate the extra modules which also comes with extra problems such as extra voltage drop throughout the board as the routing airwires get longer.

Qty	Value	Device	Package	Parts	Description	MPN
1		78XXS	78XXS	U3	VOLTAGE REGULATOR	SCD7805ACTG
2		LED3MM	LED3MM	LED1 , LED2	LED	Owned
1		PINHD-1X10	1X10	JP5	PIN HEADER	SMC-1-10-1-GT
1		PINHD-1X4	1X04	JP1	PIN HEADER	SMC-1-04-1-GT
1		PINHD-1X6	1X06	JP2	PIN HEADER	SMC-1-06-1-GT
1		PINHD-1X7	1X07	JP4	PIN HEADER	SMC-1-07-1-GT
1	0.1uf	C-US025-024 X044	C025-024X044	C3	CAPACITOR, American symbol	Owned
1	10k	R-US_0204/7	0204/7	R2	RESISTOR, American symbol	Owned
2	10uf	CPOL-USE2, 5-6E	E2,5-6E	C4, C5	POLARIZED CAPACITOR, American symbol	Owned
1	1206L 075/1 6	1206L075/16	1206L	F1	Polyfuse Resettable PTC	1206L075/16
1	16MH z	CRYSTAL-16 MHZPTH-HC 49US	HC49US	Y1	16MHz Crystal	AB308-16.000M HZ
2	220E	R-US_0204/7	0204/7	R1, R3	RESISTOR, American symbol	Owned
2	22pf	C-US025-024 X044	C025-024X044	C1, C2	CAPACITOR, American symbol	Owned
1	328P	ATMEGA328 P_PDIP	DIP28	U1	Atmel 328P	ATMEGA328P-P U
1	POWER_J ACK	POWER_JAC K	POWER_JACK _PTH	J1	Power Jack Connector	EJ503A
1	Switc h	MOMENTAR Y-SWITCH-S PST-PTH-6.0 MM	TACTILE_SWIT CH_PTH_6.0M M	S1	Momentary Switch (Pushbutton) - SPST	D6C50 F1 LFS

Table 10: Bill of Materials of the Custom PCB Microcontroller

Furthermore, adding the extra modules would increase the board complexity to a level where it would require extra layers which goes against our goal of having as low complexity board as possible along with increasing the total cost of manufacturing such a board. In the end, we decided to go with headers for these reasons as they are easy to work with. Below is a closer look at what the headers would look like on our custom PCB.

5.11.4 Bill of Materials

It is important to keep a record of the different components that go into our custom PCB microcontroller. In order to acquire parts for our printed circuit board we sourced parts from Digikey seeking the most cost effective parts that are high quality and will not fail us. For now we are ordering a single set of parts for our custom PCB because if a part fails then we will choose a different manufacturer and a new part that performs the same functionality. In order to ensure each part is operational, testing procedures will be introduced in section 6 on each part. The bill of materials below was created by generating a CSV file in Autodesk EAGLE and then editing it in Notepad++ to be compatible with an excel spreadsheet of which is displayed below. The spreadsheet features the quantity, the device name, and the manufacturing part number. If there was a part that one of the members in the group happened to own beforehand we put "Owned" as the manufacturing part number. Table 10 showcases our bill of materials

Later in section 6 we will talk about the printed circuit board layout and what went into designing a board that meets all our requirements.

5.11 Software and Interface (10-20)

Software design and implementation is a huge portion of the electrical engineering design portion of the project. One section includes the software design used on a computer running MATLAB, which dissects the data to provide the desired output as to what the object is. The other is the microcontroller which displays this data on an LCD. The two sections below explain in great detail the most important segments of code, the reasoning behind their implementation, and a chart of the software flow.

5.11.1 MATLAB Software Design

The MATLAB code behind this project is one of the most intricate and important portions of the entire project, as it is the section that actually interprets input data and realizes an output. Put more intuitively, this means taking the Raman scattered waveforms that reflect off the object and using an algorithm to deduce precisely what

object is under the laser. Without this step of the design, the user would receive an extremely large amount of data, in the size of Gigabytes, with no way of understanding its meaning. This leads into the first portion of the code, which is transferring the oscilloscope output files into matlab. The .csv file type stands for “comma-separated values”. This file type is extremely simple and hard to work with, especially within the MATLAB client. Because of this, the .csv files are converted into a MATLAB proprietary file type with a .mat extension. With this, the values are significantly more readable, and more importantly, can be altered within MATLAB. Conveniently, MATLAB has functions that make this possible. One of the simplest methods is to use the ‘csvread’ function to read a .csv file and store it as a variable in the format `csvread('filename.csv')`. This variable can then be saved using the ‘save’ function in the format `save('filename.mat','M')`. Fig 56 below displays an example of both a .csv file and .mat file, proving that converting the file type is important, as the .mat file is significantly more readable and easy to work with within MATLAB. Most of the file conversions occur within the code itself and only at the moment it is needed, rather than converting all files beforehand. This avoids creating too much delay when first booting up the program, and instead only transfers the large amount of data when it is necessary.

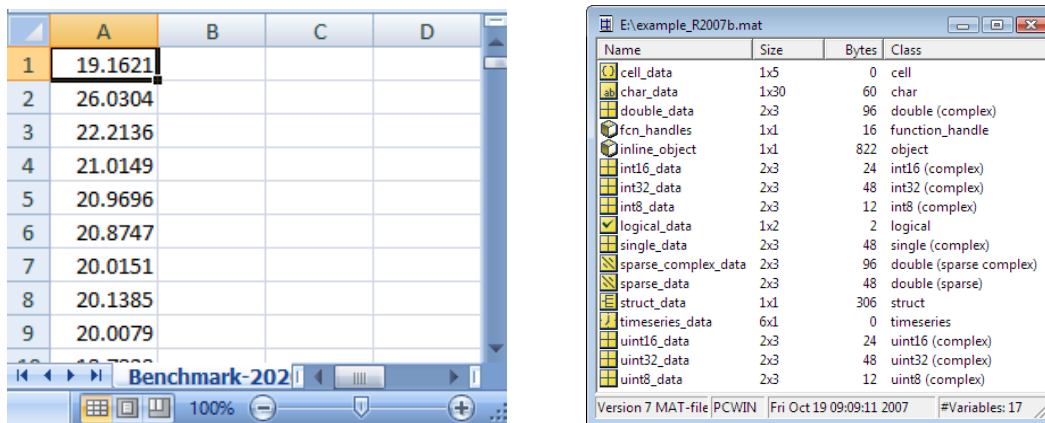

Fig 56: Comparison between .csv file (left) and .mat file (right) opened in Microsoft Excel 2007 and MATLAB R2007b, respectively

The main MATLAB file starts with some basic parameters that are meant for the user to adjust. The first of these is the sampling frequency, which needs to be at least two times greater than the bandwidth. This is known as the Nyquist rate, and in order to reproduce the output that is needed exactly as it was intended and retain all its original information without any aliasing, the sampling frequency needs to be at least double the bandwidth. Since our bandwidth is in the GHz, the sampling frequency should be a value such as 10 GHz, as this is going to be more than double the bandwidth in most cases. However, this can be changed easily if the bandwidth extends into the 9-10 GHz range. The next input tells the program which waveform data to read from in its pre-recorded files. This can be 250m, 500m, 1g, 2g, or 2.5g (where m is Megahertz and g is Gigahertz). The next is the target type, which is going to be the name of the object

under the laser being tested. This input is completely arbitrary and only needs to be understood by the user, as it is simply the name of the object. This waveform will be indexed into an array, which extends from 1 to 10001. This is how the computer itself will differentiate between the different waveforms, rather than the name. It understands that each object will have its own place inside the one-dimensional array. The last input from the user is the additional dispersion, which is between the first and second wave. This makes it easier to read the graph should there be an issue. Too low of a number here will have the waves scrunched together, and too high of a number will spread them out to a point where the graph may be hard to understand or read. The default value is 0.1373. Fig. 57 shows the difference between a graph using an appropriate additional dispersion value of 0.1373 vs one with a dispersion that is too large (0.3), reducing the amount shown on the graph.

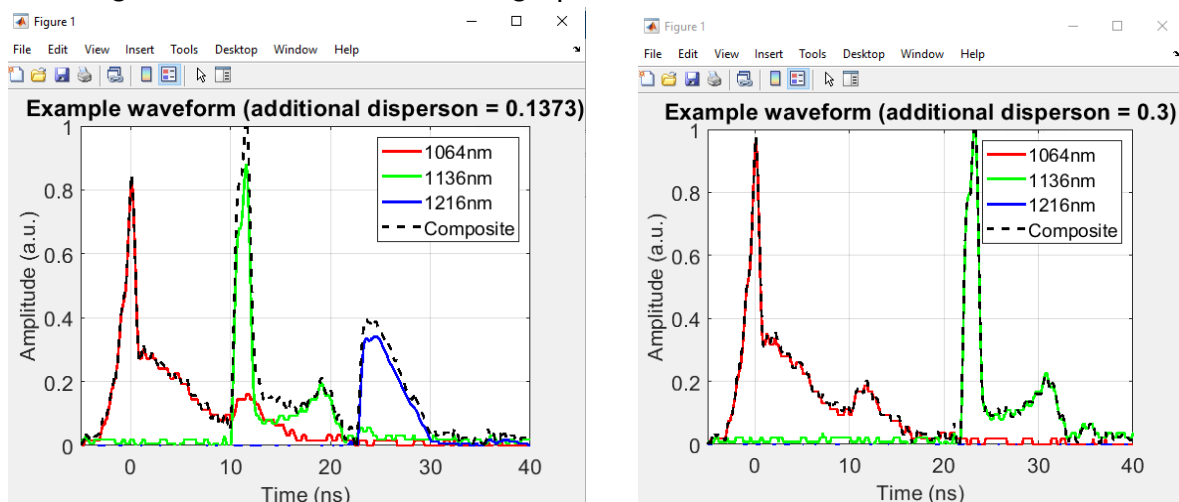

Fig. 57: Difference between the example waveform with appropriate additional dispersion value of 0.1373 versus an example waveform with a high additional dispersion value of 0.3. Both graphs are of an identical waveform.

Now that the user has input the information that will vary between each of the different objects, the rest of the program can be looked at. First, since the user inputs a specific bandwidth to be viewed, the program will load from within the file directory the pre-made waveforms and common functions that will be utilized within the algorithms. There are two different options here (though the first is sufficient for most cases): loading the natural timing of the waveform data, or the centered and pre-adjusted waveform. From there, some calculations need to be made regarding the system and modulation parameters, the average additional dispersion to insert between each of the waves (1:2 and 2:3). MATLAB then has code that will create the waveforms with the appropriate axes and title, as well as color coding the separate waves. Red (1064 nm) is the first wave, green (1136 nm) is the second wave, and blue (1216 nm) is the third wave. There are two separate graphs to be printed. The first is the more accurate example waveform. The issue with this is that the graph appears very noisy, so another graph is printed (see Fig. 58 below). This graph uses the 'mean' function to smooth out

the graph, essentially creating a waveform with no noise. This is useful because it makes the graph easier to interpret and more appealing visually for the user, while retaining all of the vital information.

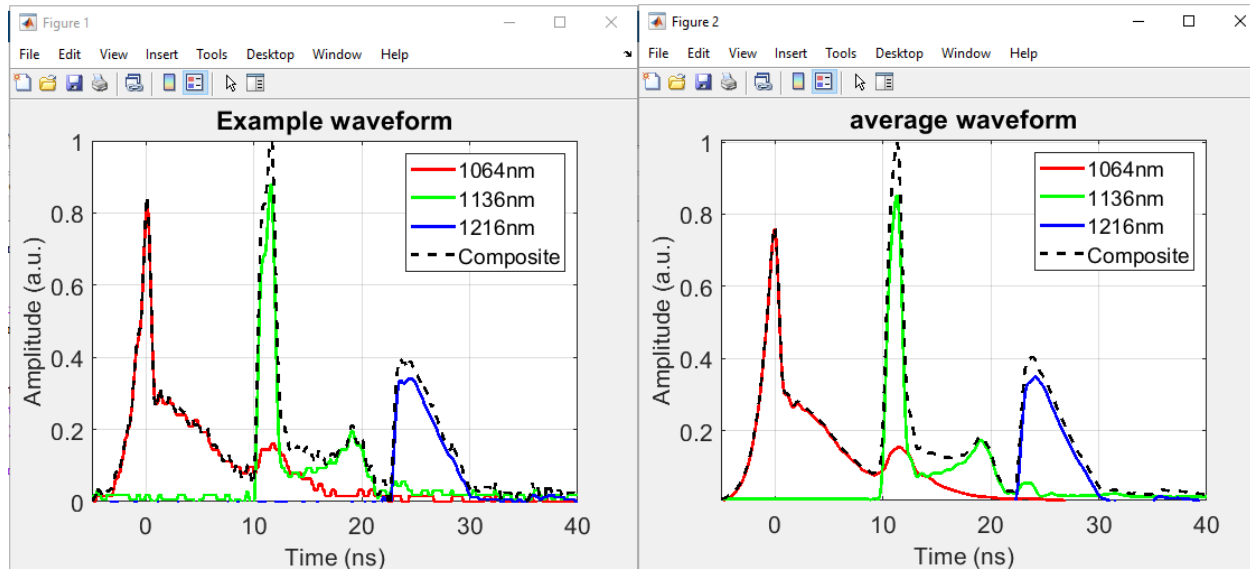

Fig 58: Comparison between the example waveform (Figure 1) and the average waveform (Figure 2), with an amplitude of arbitrary units on the vertical axis and time in nanoseconds on the horizontal axis.

The next two files of discussion relate to the comparison of the normalized root mean square error (NRMSE) and induced dispersion. The RMSE is the average value of the graph errors, and it is normalized between datasets with different scales on their axes. The induced dispersion (ID) is the scattered waveform that is actively being created from the laser, as its light is dispersed. The user inputs are almost identical to the example waveforms files; however, some new variables are introduced for the bandwidth of the detector in MHz and the number of Monte-Carlo trials. The Monte-Carlo trials use randomness to optimize the system. They slow down the program significantly, so using around 50 Monte-Carlo trials is ideal for debugging, while 500 or more is useful for finding the actual end result. This is used for the NRMSE, since it is impossible to normalize the values to the exact value, it needs to be estimated. With a high number of Monte-Carlo trials, it will be exceptionally close to this exact value. There is a main file and another file that plots the value, shown in Fig. 59.

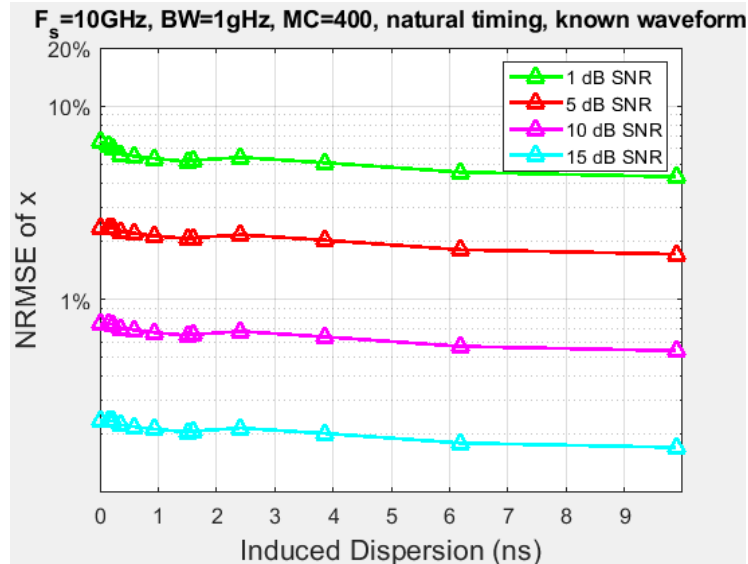

Fig. 59: Example graph of NRMSE vs Induced Dispersion in MATLAB

There are two last MATLAB codes that that are a main and a plot for NRMSE versus signal-to-noise ratio (SNR). The code for this is extremely similar in structure to NRMSE vs ID, but an example of an expected output is included in Fig. 60.

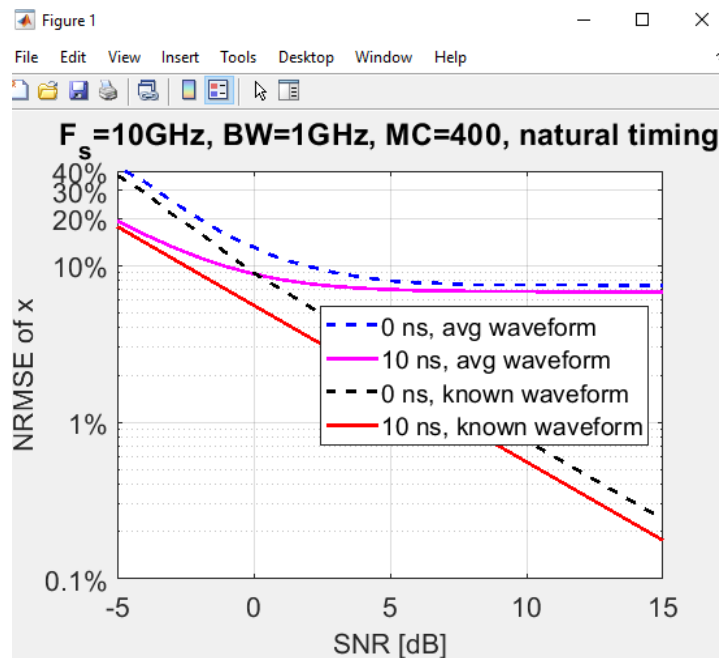

Fig. 60: Example graph of NRMSE vs SNR in MATLAB

5.11.2 Microcontroller Software Design

The software for the microcontroller mainly consists of three sub-systems: the Bluetooth module, I2C, UART, and the LCD. Individually, the codes are not too complex, though their basic structure and theory will be discussed below. For starters, Arduino code generally begins with declaring the pins and variables. Next is the setup, where the pins are selected to be either an INPUT or an OUTPUT, and initialize them to either a LOW or HIGH value (if they are digital). For this project, all of the pins are digital. Lastly, the Serial port is initiated. The command `Serial.begin(9600)` starts the output stream at 9600 baud, meaning 9600 symbols per second, where a symbol is equivalent to a bit.

Bluetooth Software Design

Bluetooth module design begins with the inclusion of the 'SoftwareSerial' library. From Arduino's website: "The SoftwareSerial library has been developed to allow serial communication on other digital pins of the Arduino, using software to replicate the functionality (hence the name "SoftwareSerial")"[15] The main purpose is to allow the ATmega processor to receive data even when it is working on other tasks, and storing it into the serial buffer. This speeds up the entire process, as the Bluetooth module does not need to wait to receive data since it can immediately send it to the processor at reception. The Bluetooth module is connected to the Rx (receive) and Tx (send) pins on the PCB. A loop begins and checks on each iteration if any data is received by using the `Serial.available()` method; if so, `Serial.read()` will take in this information. Otherwise, the loops will restart. An LED is assigned to toggle when receiving data as visual confirmation. Most Bluetooth modules, regardless of their data transfer speed, rely on code extremely similar to what is described here.

I2C Communication Setup

The I2C setup includes a .zip library named Wire.zip. From Arduino's website, this is "Two Wire Interface (TWI/I2C) for sending and receiving data over a net of devices or sensors." Basically, this allows for communication between the Bluetooth module or LCD and the I2C interface. The serial port is then opened, and a while loop will keep searching until it finds the I2C address that it needs. At this point, the initialization and variable declaration are complete, and the loop begins. The loop simply tells the module to begin sending data over the wire created earlier. The majority of the code is in the event of an error. Since the I2C module is designed to both send and receive data to check for any bit errors, any mistakes can and should be noted to the user through the console. The code prints the specifics as to the error to avoid any confusion. If no devices are detected, the program waits 5 seconds and begins searching again. By waiting, the module is able to save power by avoiding using the Bluetooth module when not in use, as it consumes a large amount of power relative to the rest of the device.

LCD Software Design

This portion of the microprocessor design begins with an inclusion of the Wire library mentioned above, in order to connect with I2C, but also a LiquidCrystal_I2C library for the liquid crystal display. Unlike the regular LiquidCrystal library, which is designed for 16 pins and no I2C connection, this is designed for I2C. However, this makes printing characters to the LCD extremely simple, as characters do not need to be coded individually. The program begins by initially constructing a method from the LiquidCrystal_I2C class and LCD object. Essentially, it is a function that tells the program how many rows and columns are included in the display. From this point, the LCD is initialized and the backlight is turned on. The loop simply prints the characters on the LCD that are entered into the program through the new lcd object. First, the first character's position is selected through lcd.setCursor. Next, the lcd.print method prints the actual characters typed into the program. This is repeated for all rows, and the program starts the loop over again to continuously reprint the values.

6 Overall Integration, PCB Design and System Testing

6.1 Optical Test Environment

Most of the optical testing will be done at CREOL, in lab A324. We were given access to the lab by Dr. Kyle Renshaw, who agreed to let us use his lab to carry out our project and work on it. The lab is suitable for all of us to be in and whenever we use the laser, we must wear laser safety goggles and make sure we take the appropriate precautions to prevent people from going into the lab while we are working there.



Fig. 61: A324 laboratory where optical testing and most of the senior design project will be done. The door to the lab will have a curtain up to prevent laser light from escaping the lab if the door is accidentally opened, and the optical table is ready for us to use once parts start arriving.

Although there is a senior design lab available for us to use at CREOL, the laser that we will be using is too powerful for us to use it in that lab. Also, there is no optical table, not enough supplies, and oscilloscopes available for us to use. In the lab that Dr. Renshaw is letting us use, we have a high-precision function generator, a DC power supply, mechanical optical mounts, screws, screwdrivers, a whole quarter of an optical table, and the rest of the lab space for us to be able to sit, bring in an oscilloscope, and do all of our testing.

6.2 Electrical Hardware Test Environment

The main location for testing electrical equipment is the Senior Design lab located in Engineering 1, Room 456. Since most test equipment will be far too expensive to purchase at home, this room will prove essential and will be a place where most of the testing will be completed. Testing algorithms, using breadboards to ensure designs are correct before they are finalized into a PCB, and using software only available at UCF's campus are the core reasons the laboratory is so important to the completion of this project. The laboratory contains various equipment, as well as various other amenities provided, such as personal lockers for storage of equipment and materials. More specifically, some of the equipment provided is in the table below:

Component Name	Component Type
Tektronix DPO 4034	Digital Oscilloscope
Tektronix AFG3022	Arbitrary Function Generator
Tektronix DMM 4050	Digital Multimeter
Agilent E3630A	Triple-Channel Power Supply

Table 11: List of equipment within the Senior Design Lab

The Tektronix DPO 4034 digital oscilloscope provided will be useful for almost every application and test required during the project, and is likely the most important piece of test equipment. While the final project will utilize a higher frequency oscilloscope for the receiving light waveforms, testing the electronics on a breadboard with the senior design lab's equipment proves more than adequate. These specific oscilloscopes can reach an analog bandwidth of 350 MHz, which is far larger than anything the electrical components of our project requires. The most important aspect of the oscilloscope will be testing various different components to ensure that the desired power is flowing through them, as too little could not provide any output and too much could cause

clipping, undesired outputs, or in the worst case, a safety hazard. The oscilloscope will easily be able to compare outputs and inputs with its four unique channels. Next to the oscilloscope, the second most important piece of equipment is the Tektronix AFG3022 Arbitrary Function Generator. The function generator will provide the inputs, since a consistent and predictable power supply is essential for testing applications using alternating current. These can supply inputs up to 25 MHz, which is still well above the amount needed for the electronics being tested. The Tektronix DMM 4050 will be able to measure DC and RMS voltages and currents, as well as resistances. Should all four channels of the oscilloscope be used, or if very quick measurements are easier, than this will be useful. One example of its usage would be finding the power across a resistor, as it is extremely simple to connect the two probes to either side to find voltage, and having the current flow through the resistor also flow through the probes to find current. Multiplying these two values will give the power, as resistors are only able to handle a certain amount. Should this value be exceeded, it would be fatal to the circuit. The next piece of electrical equipment is the Keithley 2230-30-1 Multi-Channel Programmable DC Power Supply. This equipment is self-explanatory, as it simply provides a simple way to create DC voltages and currents. Since there are only two channels from the function generator, it would not be feasible to utilize it as a DC power supply. However, the DC power supply is extremely easy to use and contains two channels; each completely unique from one another. Testing something like an operational amplifier will require a constant DC supply, and this will be the perfect hardware for this purpose.

The Senior Design laboratory also contains other equipment that may be harder to find in other lab spaces, and are more related to PCB design itself rather than testing breadboards. The first of these is the Surface-Mounted Device (SMD) Rework Station. There are many practical purposes for this tool, one of the most common being a faulty component. Other possible defects include: poor soldering, corrosion, and physical damage. However, in the event that the circuit does not work as designed on the breadboard, it is possible that some parts will need to be replaced. These mistakes are generally due to human error, but replacing them is simple with the SMD rework station provided. Generally, this works as a desoldering and re-soldering station combined into one, usually utilizing hot air from a nozzle to melt the existing solder. The area is cleaned, the new component is added, and resoldered as though it were a simple soldering station. Next, the soldering and desoldering stations (not the SMD rework station, but rather separate stations) are included for adding components to PCBs as well as removing those that are undesired. The soldering iron will include the following: the contact soldering iron, tweezers, and lead free wire, as this is much safer (although not as easy to work with). The desoldering station consists of these components: the hot air gun, which melts the existing solder; and the desoldering iron, which acts as a vacuum to pick up the melted solder alloy. Since our design includes a pre-made PCB as well as creating our own PCBs, it will be essential to solder them together into a

single component. Furthermore, unwanted circuit components that come pre-installed on the module will need to be removed at the desoldering stations. The last major piece of equipment within the senior design lab that will be extraordinarily useful is the digital microscope inspection station. Most of the components within a printed circuit board are millimeters in length and width, making them incredibly hard to work with without some visual aid. The digital microscope is able to effectively zoom in and display the output to a screen. This makes it easy for multiple members of the group to work on the circuit together, as everyone can get a close-up view of the circuit simultaneously.



Fig. 62: Senior design laboratory source: *UCF ECE website*
<https://www.ece.ucf.edu/academic-laboratories/senior-design-laboratory/>

6.3 Printed Circuit Board (PCB) design

The printed circuit board is the most essential part of the entire portion of the electrical engineering sub-system, as it controls everything that the user would need in order to make this project a practical device to detect objects. It also contains the “brain”, or the microprocessor, which is connected to every other electrical device within the system. This includes, but is not limited to: the bluetooth module, the LCD display, the LEDs, and mounting points. Furthermore, this section discusses some of the most commonly used electrical components that were not discussed in great detail before. This includes, but is not limited to: resistors, capacitors, and timing crystals. The other individual components have been discussed previously with the reason as to which

each was chosen. The schematic section, 6.3.1, shows individual components and how they are all connected to one another. In order to understand how to replicate this design, or something similar, the schematic will be available below. Section 6.3.2 discusses the other major portion of printed circuit board design, which is creating the board itself. Here, the layout of the wires and connections is made and the reasoning behind each. Should a user or customer need to exactly duplicate the design, this is where they would be directed towards.

6.3.1 Board Design

There are many aspects and design philosophies that go into designing a printed circuit board after creating a schematic and to learn these techniques we watched and practiced with tutorials that featured embedded microcontroller PCB design. In doing so we were able to then go on to create our own board using Autodesk EAGLE with which we had the most experience with. Our main goal in designing this board is to keep it as simple as possible in layout so to keep the cost down along with reducing any issues we might run into by having a more complex board whether that might be on the manufacturing side or the soldering side that we will be performing in the next semester of senior design.

To design the board we started by adding the power module to the bottom of the board which consists of the power jack, the fuse, a voltage regulator and its accompanying capacitors along with a led and resistor for power check. All components on this board are through hole with the exception of the fuse which is mounted at the bottom of the board because this is a y layer board with the copper pour at the bottom layer. This is all routed with a VCC that is thicker than the rest of the air wires so as to be able to hold a higher voltage. Another important aspect of the board's power system is that we added a copper pour that is connected to ground. This makes it so that any point touching the copper pour is grounded making it easier to route the board because there are a lot less wires needed to connect to ground. This copper pour makes it so that we do not have to have a 2 layer board and can do everything on one layer which reduces the cost and makes the board easier to work with. We also decided to put the reset button next to the power check LED for convenience sake. We put the ATmega328p-pu at the center because it is the biggest component on the board and also has the most pinouts that connect to other components. On either side of the ATmega328p-pu we added the headers in a layout that had no crossing air wires. Furthermore, we also included an LED and a 16MHz crystal oscillator with accompanying resistors and capacitors on the left and right side of the board respectively. Some clever routing procedures that we included in the design of the printed circuit board included routing VCC under the ATmega328p-pu and under a resistor so that VCC can reach all the different pins that require a connection to VCC without having to cross another wire or go around the whole setup.

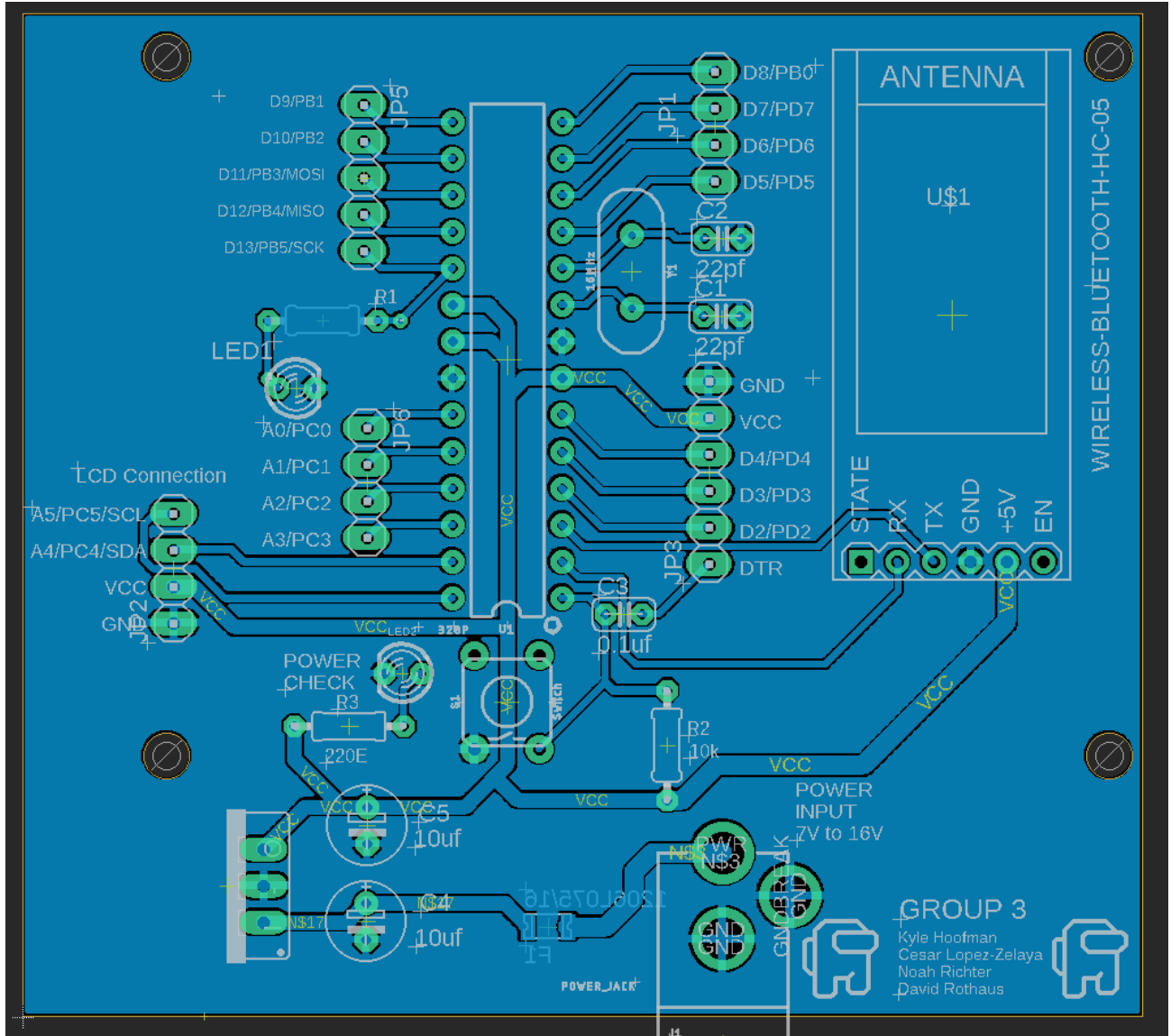

Fig. 63: Custom Microcontroller PCB featuring a ATmega328p-pu that will be connected to and control the external modules

It is important that the air wires aren't too long because as they get longer they introduce more voltage drop and passive resistance. On the top layer of the board is a silk screen with identifiers for each component of the board including each pinout that is connected to a header. Also included in the silk screen is the group number, our group member's names and an accompanying design. Four mounting holes were also included in the design of the board. The board size is 50mm by 70mm which is very similar to the Arduino Uno board.

Below is the full custom PCB design that we will be using for our project of which we will go through the design process we went through.

6.4 Electrical Hardware Testing

Testing hardware is very important especially before you put your device together because adding a defective part to your device will waste a significant amount of time and money because you will then have to take apart the device then order a new functioning part and re-implement it into the device. By testing each external module beforehand we will be able to avoid this issue. Unfortunately the labs at UCF were closed when we reached the testing phase of our project this semester and will be reopening in January 2021. This is an issue because an oscilloscope would have been

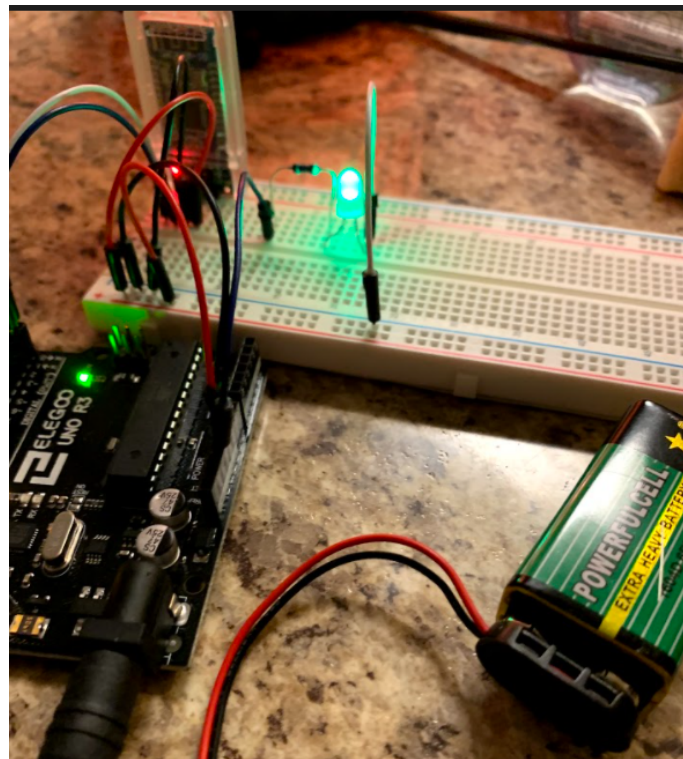

Figure 64: Showing the test of the bluetooth by lighting a green LED

useful in testing some of our power components like a voltage controller. Below are the different tests for the external modules we have received from our online orders.

To test the HM-10 bluetooth module we first connected it to an arduino UNO R3 which is very similar to the custom PCB microcontroller that we will be building for this project. We also connected a green LED in series with a resistor to a digital pin on the Arduino UNO. We loaded code onto the Arduino via USB to start the process of connecting bluetooth to a laptop and controlling the LED wirelessly. After the Arduino was programmed and the bluetooth was successfully paired with the laptop we connected the arduino to a 9 volt battery and set it approximately 5 meters away from the laptop. We were still able to control the LED wirelessly proving that the HM-10 bluetooth module worked successfully and can be implemented into our project. Next we tested the 20x4 LCD display with I2C integrated module which is shown below.

For the 20x4 LCD display with I2C adapter the testing was relatively simple. We also tested this external with an Arduino UNO R3. We were able to connect the LCD display directly to the header pins of the Arduino without the use of a breadboard. We were able to load code onto the arduino and instantly see results shown above. This proves that our 20x4 LCD display with I2C adapter works successfully and can be implemented in our project.

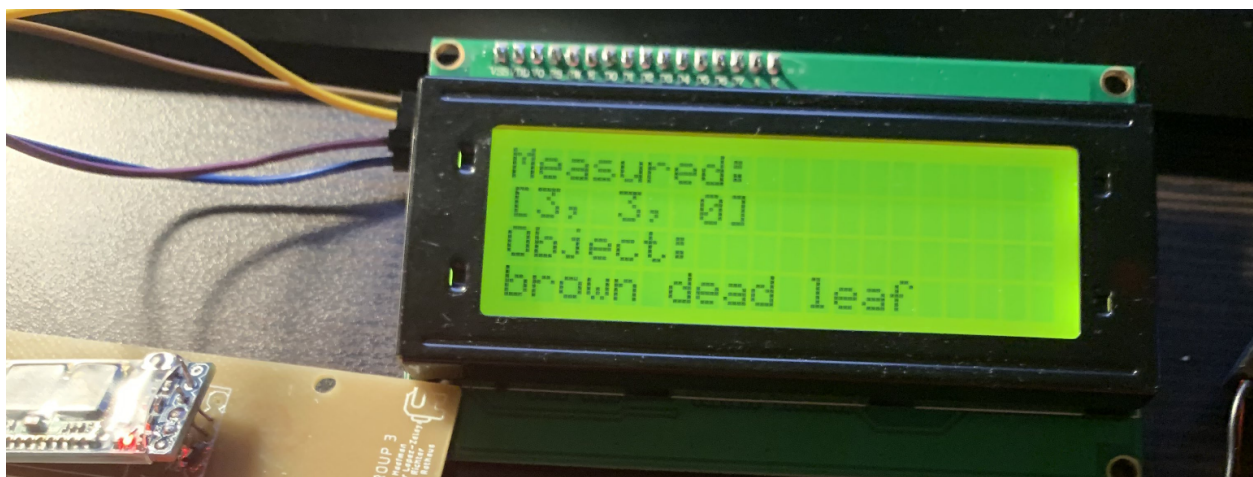

Figure 65: Showing the test of the 20x4 LCD display with an I2C adapter

6.5 Optical Hardware Testing

At the moment, no optical testing was done at UCF. The primary reason why is because part orders have not been able to be placed due to funding being delayed by congress. The only thing we can do at UCF for the time being is check how well the

optics we borrowed look and make some qualitative comments about them. In the following images, the silver mirrors, mirror holders, and lenses were examined.

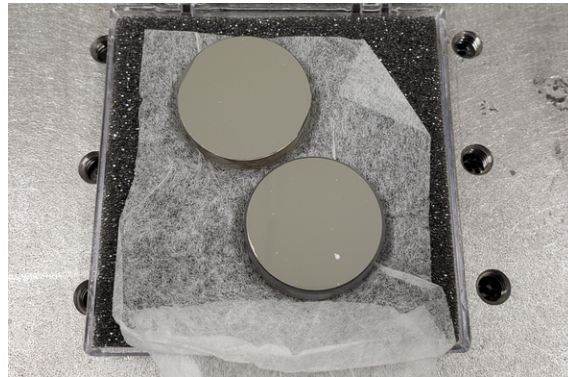

Fig. 66: Thorlabs 1" silver mirrors. Notice the laser induced damage on the surface of the bottom mirror, while the top one has slightly more damage on its surface but not as deep.

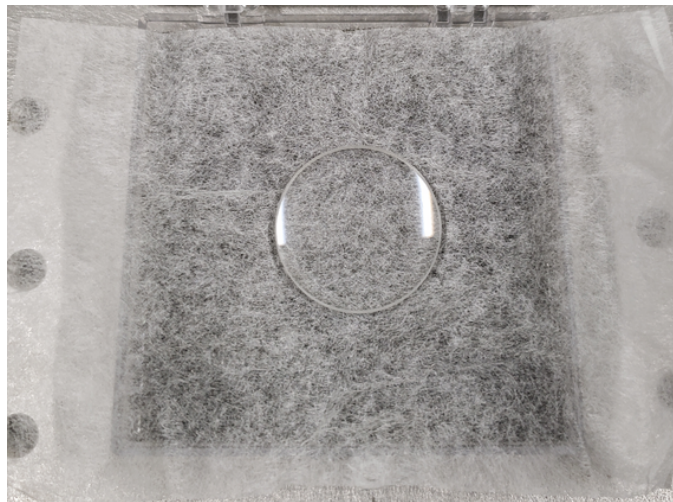

Fig. 67: Newport KBX061 bi-convex uncoated lens for collimating the Raman output. No laser induced damage on its surface and good transmission up to 2000nm wavelength.

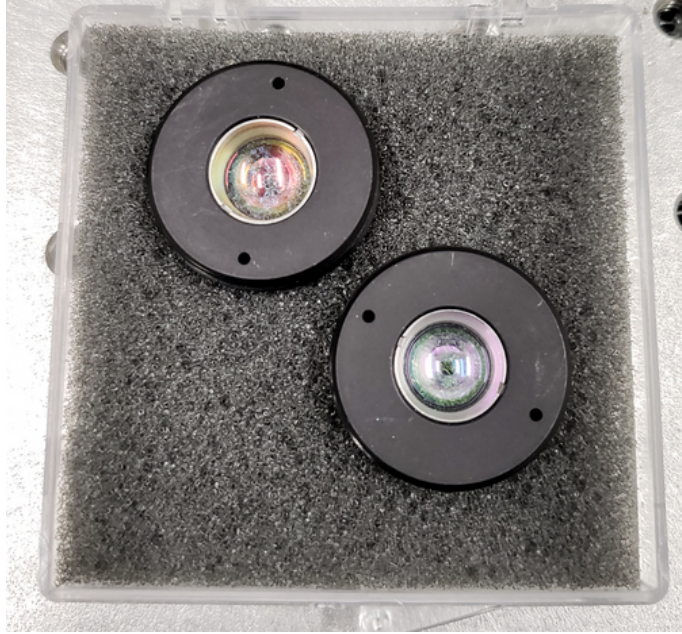

Fig. 68: Pair of Thorlabs A240TM-C lenses without any visible laser damage that would impact their performance.

As it can be seen in the pictures above, the most damaged components were the mirrors. This is to be expected since they were previously used in high-power laser experiments. Still, these will serve their purpose to align our pump laser. What we have to do when aligning it is use an IR card, make sure that the beam is hitting the mirror and not a burnt spot. Just to note, burnt spots in the mirror will be sources of diffuse reflections, which are terrible for alignment purposes. Upon checking all optical components available at the moment, they were mounted on posts and put in the optical table.



Fig. 69: All optics mounted and ready to go when the pump laser arrives.

Despite not having the pump laser, we were notified that it works as intended. Testing for it was done at Eglin AFB and its output power, divergence, and other characteristics and components that belong to it were tested.

From just examining the pump laser, the following information was obtained:

- Manufacturer: Lockheed Martin (formerly Aculight)
- Model Number: M31PL-1065-20-3.0-0.3-ST
- Serial Number: 1009
- Connector type FP/APC

Then, the pump laser was characterized:

- Max Average Power: 1.2W (50Khz)
- PRF: 20KHz to 50KHz
- Pulse Width: 3.0nsec (FWHM)
- Beam Size: 3.6mm (D4sigma), 1.85mm(50%peak) (~145mm from collimator aperture)
- Divergence: 0.36mr (D4sigma) (yes 0.36), 0.25mr (50%peak)

Note, the values obtained above were measured by using the original components that the laser came with. One small issue with this is that components like the collimator were a bit outside of specifications, which means that by changing that part, performance could be slightly improved. The optics in the output side of the pump are currently a combination of collimator and polarizer; comprised of the Thorlabs SM1PM10 with GL10-C26 Polarizer (1064nm V-coating) and a Thorlabs F810APC-842, 842 nm FC/APC Collimation Package, NA = 0.25, f = 36.18 mm, AR coated 650nm – 1050nm. Without the collimator, the output power increased by 17%.

Even though this is not a big issue, a better collimator can be used (and will be purchased prior to bringing the pump laser to UCF). The better collimator is the F810APC-1064 - 1064 nm FC/APC Collimation Package, NA = 0.25, f = 36.60 mm, which will combine properly with the existing SM1PM10 with GL10-C26 Polarizer. Since this collimator will have a slightly larger beam size (8mm), then a slightly larger isolator is needed, which is the ISO-FRDY-08-1064-W from Newport. For more details about these parts, see section 5.3, 5.4, and 5.5.

Knowing that the pump laser works and that new new components that will be soon ordered will improve its output by 17% and make the divergence really small, enables us to infer that by the time we set everything up and test it ourselves in the lab will be cut down significantly. This will let us get started right away on the optical setup and begin the calibration stage promptly.

7. Administration. (5-10 pages)

There are two main components to describe the process of working together as a team, sponsor, and others in leading and organizing the team. The first is the milestone discussion, and the second is the budget and finances. For an expensive project such as this one it is important to know how the components are paid for. The milestone discussion is an overview of the scheduling of our project and all its specific stages, such as: project approval, design, presentation, etc. The chart will give a quick overview of the stages, while the description below goes into detail about the specifics of each stage and how they are accomplished. The second portion is the budget and finances discussion, where a list of all the components and their costs are listed. It is divided between the electrical and optical components in two separate graphs. Included in this section are the sponsors and UCF faculty members who are able to lend us parts for the completion of our project. Their contributions are important to the success of this project and their names and input are fundamental to the project and need to be documented.

7.1 Milestone Discussion

Milestone	Semester	Completion date
Project Idea finalization	Fall	09/23/2020
Design	Fall	11/10/2020
Acquire parts and lab space	Fall	*12/01/2020
Documentation	Fall	*12/08/2020
Building and prototyping	Spring	*01/2020
Testing and calibration	Spring	*03/2020
Project finalization	Spring	*04/2020
Presentation	Spring	*04/2020

Table 12: Complete list of all milestones for the project, as well as their individual completion date. **denotes expected completion date*

Our initial project milestone was getting our idea finalized. The original divide and conquer document contained a brief explanation of how the experiment would work, and it also compared it with other ideas in the event our main idea did not appear feasible to the professors reviewing the document. Though there were some doubts as to the risk in the cost and reasonability of the project, displaying the engineering possibilities (discussed in more detail throughout the document) and providing supporters and sponsors were willing to lend a hand meant the project could continue. Soon after, the main idea was officially approved, and work on the multispectral Raman laser pressed on. This also meant moving towards the next step in the project: completing the design before working on campus to complete the physical assemblance of the laser and detector.

The design process is a complicated and essential component of ensuring the laser works with few hiccups to interrupt the completion. Should corners be cut during the design process, every subsequent stage of the project would be put in jeopardy of being completed incorrectly. As design continues, it is imperative to keep a good record of every aspect of the project. Keeping good documentation early on during fall will leave less to do over spring during testing and building the design. Being pressed for time during later portions would only ensure the incompleteness of the project, so not procrastinating is essential. As we design, comparing and contrasting the different engineering and marketing requirements narrows down the parts and design that we will complete the project with. The final design is completed and ready for testing before the end of Senior Design I. This leads into the next portion, the acquisition of both photonics and electrical parts, as well as a designated location for testing, troubleshooting, and benchmarking.

As fall comes to an end, the design will have been completed entirely, allowing us to not only begin purchasing components, but to start building the laser system around November (or December). Orders for photonics components placed in October arrive by November, and electrical components from created schematics, as well as any other components, such as a microcontroller. All components purchased allow for testing to begin at the closing end of Senior Design I. Furthermore, various professors have been in contact at UCF who are graciously willing to lend any other lab supplies and photonics laboratory locations. Once we have finished purchasing the parts and start building the system, this will conclude the fall semester and Senior Design I.

Though documentation will continue to be updated to reflect anything occurring with the project, the vast majority of documentation is completed by December. Wrapping up the vast majority of documentation early allows for significantly more time to focus specifically on the hardware and software portions of the project. Since no one can assume their project will work immediately after the design process is complete, it is imperative to leave ample time to fix any errors and troubleshoot problems and issues

that may arise. Essentially, research, planning, and reporting is completed at the end of Senior Design I, and Senior Design 2 can be left to testing and integrating the design.

7.2 Budget and Finance Discussion

As stated in the cover of this document, this is a sponsored project. Most of the expensive components, like the laser and PM-SM fiber, will be loaned to the group by the Air Force Research Laboratory. UCF professors will help us with lab space, an ADC, and optical components. Since this project requires the use of a class IV laser, it will be done in Dr. Kyle Renshaw's laboratory at CREOL. The ADC (oscilloscope) will be provided by Dr. Guifang Li, and the rest of the opto-mechanical components like mounts, posts, post-holders, mirror holders, lenses, high-power meter, and more, will be loaned to us by Dr. Peter Delfyett.

The table presented below lists the parts that we had to purchase, either as a group, with UCF or with AFRL, as well as their prices. Keep in mind that the overall cost of the project would have gone up exponentially (\$200K+) if we had to purchase everything, including the laser and the oscilloscope.

Note: For a complete discussion of all parts, refer to section 5.

TABLE OF PARTS

ITEM	PART #	Description	QUANTITY	PRICE ESTIMATE (PER-ITEM)
DC Power Supply for MCU	Agilent E3620A	Output Ratings (Maximum current is derated 3.3% per °C from 40°C to 55°C), Output 1: 0 to 25 V, 0 to 1 A, Output 2: 0 to 25 V, 0 to 1 A, Power (max): 50 W, Ripple & Noise from 20 Hz to 20 MHz, Normal Mode Voltage rms: 350 μ V, Peak-to-Peak: 1.5 mV, Load & Line Regulation, 0.01% + 2mV, Meter Resolution, Voltage: 10 mV (0-20 V), 100 mV, (>20 V), Current: 1 mA	1	10\$
1.064 μ m pump laser	Lockheed Martin: M31PL-1		1	\$30,000

	0 5-20-3.0- 0.3-ST (Telesto)			
Optical isolator	ISO-FRD Y-05-106 4-W	Faraday Optical Isolator, High Power, 5mm, 1064nm, ½ Waveplate	1	\$1650
Microscope Objective Lens	LMH-20x - 1064	High-Power MicroSpot Focusing Objective, 20X, 980 - 1130 nm, NA = 0.40	1	\$1659.97
Mounted Polarizer	LPNIRB1 00-MP2	Ø1" SM1-Mounted Linear Polarizer, 650 - 1100 nm	1	\$705.99
Half-wave plate	AHWP10 M-980	Ø1" Mounted Achromatic Half-Wave Plate, SM1-Threaded Mount, 690 - 1200 nm	1	\$919.44
Fiber Adapter Plate	SM1FC	FC/PC Fiber Adapter Plate with External SM1 (1.035"-40) Threads, Wide Key (2.2 mm)	2	\$61.50
Focusing Lens	A230TM- C	F=4.51 mm, NA=0.54, Mounted Rochester Aspheric Lens, AR: 1050-1620 nm	1	\$90.09
Focusing Lens	KBX061	Uncoated, 1 inch (25.4 mm) diameter, N-BK7 bi-convex lens with an effective focal length of 88.3 mm	2-4	\$168
Single Mode Fiber Launch	MBT610D	Single Mode Fiber Launch with Variable V-Groove Clamp	1	\$1680.86
Rotation Mount	RSP1X15	Rotation Mount for Ø1" (Ø25.4 mm) Optics, 360° Continuous or 15° Indexed Rotation, 8-32 Tap	2	277.84
PM-SM fiber	PM980-X P	970 - 1550 nm PM Fiber, 6.6 µm MFD	100	\$1894.00

Multimode Fiber	M67L01	Ø25 µm, 0.10 NA, FC/PC-FC/PC Fiber Patch Cable, 1 m	2	\$212.10
Lens Cell Adapter 1	S1TM12	SM1 to M12 x 0.5 Lens Cell Adapter	2	\$47.72
Lens Cell Adapter 2	S1TM09	SM1 to M9 x 0.5 Lens Cell Adapter	1	\$23.86
Collimating lens	F810APC - 1064	1064 nm FC/APC Collimation Package, NA = 0.25, f = 36.60 mm	1	\$265.12
Compact Flexure Plate Clamp	PC2	Compact Flexure Plate Clamp, 1/4"-20 Tap	1	\$22.07
Diffraction Grating	GR25-03 10	Ruled Reflective Diffraction Grating, 300/mm, 1 µm Blaze, 25 x 25 x 6 mm	1	\$114.72
Diffraction Grating Mount	KM100C	Kinematic Mount for up to 1.3" (33 mm) Tall Rectangular Optics, Right Handed		\$100.49
Lens Mount	LMR1	Lens Mount with Retaining Ring for Ø1" Optics, 8-32 Tap	5	78.45
FC/PC fiber connector			4	15\$
Beam stopper	BT610	Beam Trap, 400 nm - 2.5 µm, 30 W Max Avg. Power, Pulsed and CW, 8-32 Tap	2	\$627.80
Safety goggles	LG11		2	\$758.35

Table 13.1: Table of photonics parts

Table of Electronic Parts

Manufacture d PCB		Green 1 layer 69.7mm x 49.5mm board	1	\$15
Voltage Regulator	SCD7805 ACTG	IC VOLT REG 1A 5V TO220	1	\$0.52
1x4 Header	SMC-1-0 4-1-GT	MACHINE PIN SOCKET 4P 1.00MM PIT	1	\$0.33
1x6 Header	SMC-1-0 6-1-GT	MACHINE PIN SOCKET 6P 1.00MM PIT	1	\$0.43
1x7 Header	SMC-1-0 7-1-GT	MACHINE PIN SOCKET 7P 1.00MM PIT	1	\$0.46
1x10 Header	SMC-1-1 0-1-GT	MACHINE PIN SOCKET 10P 1.00MM PI	1	\$0.65
PTC Reset Fuse	1206L075 /16WR	PTC RESET FUSE 16V 750MA 1206	1	\$0.91
16MHz Crystal Oscillator	AB308-1 6.000MH Z	CRYSTAL 16.0000MHZ 16PF TH	1	\$0.51
ATMEGA32 8P Microcontrol ler	ATMEGA 328P-PU	IC MCU 8BIT 32KB FLASH 28DIP	1	\$2.08
Power Jack	EJ503A	CONN PWR JACK 2.1X5.5MM SOLDER	1	\$1.27
Reset Button	D6C50 F1 LFS	SWITCH PUSH SPST-NO 0.1A 32V	1	\$1.10
Bluetooth Module	ML-HM-1 0		1	\$9.99
Microcontrol ler Programmer	CP2102		1	\$7.98

20x4 LCD Display	3-01-017 5-A		1	\$7.99
9V Battery			1	\$2
Battery Connector			1	-
Total Cost	-	-	-	\$51.22

Table 13.2: Table of electronics parts

Total price of all parts (estimate based on purchased only) = 8,000\$

8. Conclusion

CAD will be a very ambitious and interesting device to make and hopefully see being implemented in future LADAR systems if the technology improves. Compared to conventional technologies, which just map scenes with little information about what is actually being mapped, CAD would be an interesting and inexpensive solution to include in object identification. Not only will it be capable of emitting many different wavelengths, it will use the shape of those pulses in time to tell them apart without the use of diffractive optics and be able to look at the amplitudes of the reflected wavelengths to be able to classify or identify objects.

Similar to CAD, as mentioned in the introductory part of this paper, Ausley et al. were able to use a hollow-core photonic bandgap fiber filled with hydrogen to obtain a clean Raman emission capable of being used for spectral reflectivity measurements after post-processing in Matlab. The main difference between their platform and ours is the Raman gain medium, which in our case is a PM-SM silica fiber. This means that the wavelengths that they obtained versus ours are slightly different due to the Raman gain. Also, spectral broadening of the silica emission might be a problem, so appropriate modulation of input laser power will be used to control what Stokes lines will be used by our device. Another reason why we want to use a PM-SM fiber for this too is because it will prevent us from getting polarization scrambling, which is crucial for a good Raman emission, and thus making the overall device work properly. At this point into the planning of how this is going to be built and work, whether our fiber will have endcaps or not is debatable. It might take too long to get the endcaps on the fiber on top of Thorlabs not being able to maybe get us the fiber in time. A limiting factor about this will be the maximum peak power that we will be able to use. It will go from around 1kW to ~300W peak power with a 3ns pulse duration and 20KHz rep rate.

Included in the project will be a custom PCB that will feature an ATMEL ATmega328P-PU which is very popular on a lot of prototyping boards hence one of the reasons we chose this microcontroller unit. Our custom PCB microcontroller will have similar functions to that of an Arduino UNO rev3. Examples of the capabilities of what an Arduino UNO and our PCB can do are use I2C and UART serial communication protocols to connect to external devices. These external devices include a bluetooth module and a display. With the bluetooth module we were able to find one in the HM-10 which easily connects to an Arduino and pairs with a PC so that the PC can send commands to the Arduino. The HM-10 also lets us have an extensive range that we tested up to 10 meters but may work up to 100 meters. The display is a simple liquid crystal display that is in the layout of 20x4 which is up to 80 characters. This LCD

in particular we decided to pick one that included a soldered on I2C adapter so to minimize wire requirements and to make the software controlling of the device simpler.

With each component; custom PCB microcontroller, the bluetooth module, and the 20x4 LCD display we will be able to create a way to access information that the CAD system outputs while not having to be tethered to the post-processor or computer. We ended up making some changes in part selection after testing and receiving some parts from the manufacturers. For example we originally wanted to use an OLED display to display info but after ordering and receiving an OLED screen we decided that it was much too small for our liking and went with a larger 20x4 LCD with I2C adapter.

Overall, we didn't have that many constraints too. The Air Force just wants to see how well this device works and how feasible it is to obtain spectral reflectivity measurements from different objects, such as leaves, plants, and dirt, by using the temporal shape of the Raman emission from a silica fiber. Therefore, we have set out to build this laser with the best of our abilities, and make a Bluetooth-connected electrical subsystem that goes with it to make the identification of objects and detection an easy task.

Originally, we were anticipating building the device and testing it out by the end of the fall semester or the beginning of December. Unfortunately, delays with funding from congress have made this deadline a bit hard to achieve. Fortunately, we borrowed some optics from Dr. Richardson's group at CREOL and started putting them up on the optical table so that when the items for this device are ready, we can start building it and have it ready to go as soon as possible. Therefore, we expect to have almost everything, if not everything, by the end of December and have the calibration stage done by the end of January the latest. There is not really a time constraint set by our sponsor, so the only "real" time constraint we have are the deadlines of the spring 2021 semester.

In conclusion, a laser system capable of obtaining spectral reflectivity measurements and identifying objects was designed. This device uses an optical subsystem to generate Raman-based waveforms that are all distinct in time. With this characteristic, each individual wavelength can be detected and captured with a single detector and be sent to an oscilloscope after scattering off of an object. After some post-processing done on Matlab via a signal analysis algorithm, the spectral content of the objects can be saved and then used to let the system know that specific object was identified. This information will be passed to the electrical subsystem via a bluetooth module, where an LCD screen connected to a PCB will display the spectral reflectivity information, the object identified, and possibly range. Despite there being no constraints from our sponsor, we made sure to try to lower the cost as much as possible by using parts that are not as expensive, but that still perform really well. We hope that after the fall

semester, we can quickly begin building the optical subsystem as soon as the parts arrive by mid- to late December and have the waveforms characterized by the end of January in the spring. Then, once all that is taken care of, start characterizing objects (i.e. plants, dirt, etc.) to then show that the system works as intended.

Appendix

A1 Works Cited

- [1] Powers, M. A., Davis, C. C., "Spectral LADAR: active range-resolved three-dimensional imaging spectroscopy," *Appl. Opt.* 51, 1468-1478 (2012).
- [2] Gong, W., Sun, J., Shi, S., Yang, J., Du, L., Zhu, B., Song, S., "Investigating the Potential of Using the Spatial and Spectral Information of Multispectral LiDAR for Object Classification," *Sensors* 15(9), 21989-22002 (2015).
- [3] Douglas, E. S., Martel, J., Li, Z., Howe, G., Hewawasam, K., Marshall, R., Schaaf, C. L., Cook, T., Newnham, G. J., Strahler, A., Chakrabarti, S., "Finding Leaves in the Forest: The Dual-Wavelength Echidna Lidar," *IEEE Geoscience and Remote Sensing Letters* 12(4), 776-780 (2015).
- [4] Danson, F. M., Gaulton, R. Armitage, R. P., Disney, M., Gunawan, O., Lewis, P., Pearson, G., Ramirez, A. F., "Developing a dual-wavelength full-waveform terrestrial laser scanner to characterize forest canopy structure," *Agricultural and Forest Meteorology* 198–199, 7-14 (2014).
- [5] "What is Raman Spectroscopy? - HORIBA."
<https://www.horiba.com/en/en/raman-imaging-and-spectroscopy/>. Accessed 21 Oct. 2020.
- [6] "What is Raman spectroscopy? - InPhotonics."
<https://www.inphotonics.com/raman.htm>. Accessed 23 Oct. 2020.
- [7] "Infrared Spectroscopy - MSU chemistry."
<https://www2.chemistry.msu.edu/faculty/reusch/virttxtjml/spectrpy/infrared/infrared.htm>. Accessed 23 Oct. 2020.
- [8] Luke Ausley, Christian Keyser, and Richard Martin "Temporally multiplexed multispectral ladar with Raman-based waveforms", *Proc. SPIE 10636, Laser Radar Technology and Applications XXIII*, 106360C (10 May 2018); <https://doi.org/10.1117/12.2316351>
- [9] L. Cohen and Chinlon Lin, "A universal fiber-optic (UFO) measurement system based on a near-IR fiber Raman laser," in *IEEE Journal of Quantum Electronics*, vol. 14, no. 11, pp. 855-859, November 1978, doi: 10.1109/JQE.1978.1069714.
- [10] "bluetooth-controlled-messenger-lcd"

<https://create.arduino.cc/projecthub/Vishalsoniindia/bluetooth-controlled-messenger-lcd-5da888>. Accessed 6 Dec. 2020.

[11] Agrawal, G. P. (2012). Nonlinear fiber optics 5th ed.

[12] Okamoto, K. (2006). Fundamentals of optical waveguides. Academic press.

[13] "Contents - open-std."

<http://www.open-std.org/jtc1/sc22/wg14/www/docs/n1124.pdf>. Accessed 11 Nov. 2020.

[14] "Fiber lasers: The state of the art - Laser Focus World." 1 Apr. 2012,

<https://www.laserfocusworld.com/test-measurement/spectroscopy/article/16549567/fiber-lasers-fiber-lasers-the-state-of-the-art>. Accessed 13 Nov. 2020.

[15] "Libraries - Arduino." <https://www.arduino.cc/en/reference/libraries>. Accessed 5 Dec. 2020.

A2 Datasheets

Energizer 9 V Battery Specifications:

<https://www.datasheetarchive.com/pdf/download.php?id=16aa6282917a060bb238bcd33ebbd82c1e5c1f&type=P&term=ANSI-1604A>

Keithley 2230-30-1 Multi-Channel Programmable DC Power Supply:

<https://assets.testequity.com/te1/Documents/pdf/keithley/2220-2230-ds.pdf>

Lockheed Martin - Telesto

<https://www.yumpu.com/en/document/read/29395945/telesto-tm-lockheed-martin>

Rayovac 9 V Battery Specifications:

<https://content-eu-7.content-cms.com/9044a799-c194-4640-9cdc-9b5096daacf4/US/Datasheets/99999999999991287269-Datasheet-override-1287269.pdf>

Tektronix AFG3022 Arbitrary Function Generator:

<http://www.testequipmenthq.com/datasheets/TEKTRONIX-AFG3022B-Datasheet.pdf>

Tektronix DPO4034 Digital Oscilloscope:

<http://www.testequipmenthq.com/datasheets/TEKTRONIX-DPO4034-Datasheet.pdf>

Tektronix DMM4050 Digital Multimeter:

<https://www.tek.com/datasheet/dmm4050-4040-digital-multimeter>